

*2007 ECI Conference on The 12th International Conference on  
Fluidization - New Horizons in Fluidization Engineering*

Vancouver, Canada

Editors: Franco Berruti, The University of Western Ontario, London,  
Canada

Xiaotao (Tony) Bi, The University of British Columbia, Vancouver, Canada

Todd Pugsley, University of Saskatchewan, Saskatoon, Saskatchewan,  
Canada

---

*Year 2007*

*Paper 8*

---

## Liquid Feed Injection in a High Density Riser

S. Gehrke\*      K. E. Wirth†

\*Institute of Particle Technology, Erlangen

†Institute of Particle Technology, Erlangen

[http://services.bepress.com/eci/fluidization\\_xii/8](http://services.bepress.com/eci/fluidization_xii/8)

Copyright ©2007 by the authors.

# Liquid Feed Injection in a High Density Riser

## **Abstract**

First investigations on liquid feed injection in a high density circulating fluidized bed of FCC particles were done by means of fast responding thermocouples, capacitance and conductivity probes. The results imply very limited radial mixing between dry solids, wet solids and liquid for the injection parallel to the hot up-streaming gas-solid flow.

## LIQUID FEED INJECTION IN A HIGH-DENSITY RISER

S. Gehrke, K.E. Wirth  
 Institute of Particle Technology  
 Cauerstrasse 4, Erlangen, 91058, Germany  
 T: +49 9131 8529403, F: +49 9131 8529402,  
[S.Gehrke@lfg.uni-erlangen.de](mailto:S.Gehrke@lfg.uni-erlangen.de), [K.E.Wirth@lfg.uni-erlangen.de](mailto:K.E.Wirth@lfg.uni-erlangen.de)

### Abstract

First investigations on liquid feed injection in a high density circulating fluidized bed of FCC particles were done by means of fast responding thermocouples, capacitance and conductivity probes. The results imply very limited radial mixing between dry solids, wet solids and liquid for the injection parallel to the hot up-streaming gas-solid flow.

### Introduction

In chemical engineering liquid feed injection especially in high-density risers is of great economic importance. The most common industrial application is the catalytic cracking (FCC). The proper injection of the liquid educt and the mixing process of educt and catalyst have significant influence on the yield and the selectivity of the process (1). Investigations on the injection into dilute gas-solid flows and into bubbling fluidized beds are present in literature (2) (3). Up to now, no experiments on liquid feed injection into high-density risers have been published. Hence, the development of the spray region inside a pilot-scale riser has been characterized.

### Experimental setup

The experimental setup is shown in figure 1. Two Roots blowers provide air which is preheated up to 200°C by an electric heater. The air enters the riser via three inlet pipes and mixes with the

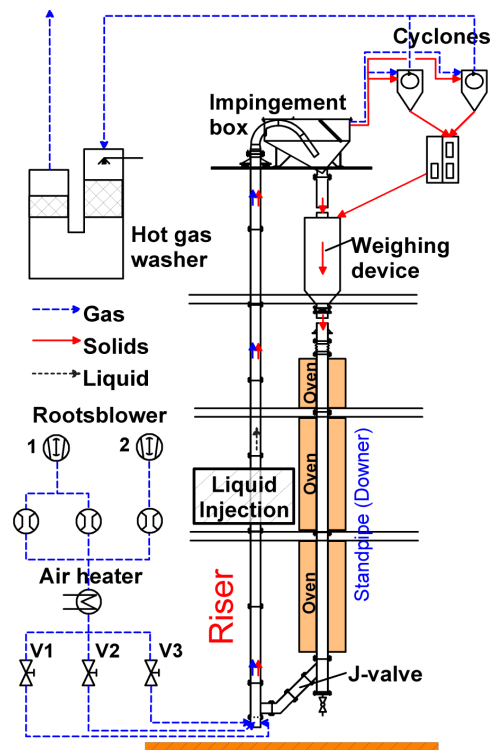

Figure 1: Experimental setup

solids from the standpipe. The inner diameter of the circulating fluidized bed is 190 mm and the height of the riser section is 11.3 m. Gas and solids are separated at the top section by an impingement box and second stage cyclones successively. The hot gas is cooled by a gas washer. To measure the solid mass flux, the solid can be collected in the weighing hopper. Otherwise the solid enters the standpipe section of the plant. There, three electric ovens are installed to preheat the solids, in the given experiments spent FCC particles with a mean diameter of  $d_p = 78 \mu\text{m}$  and an apparent density  $\rho_s$  of  $1600 \text{ kg/m}^3$ . The specific mass flux  $G_s$  was about  $420 \text{ kg/m}^2\text{s}$  at a temperature of  $200^\circ\text{C}$ . Water was injected in the middle of the reactor via a single fluid nozzle which was set parallel to the uprising stream of hot catalyst particles. (cp. figure 2). The mean solids concentration was determined via pressure transducers. The value at the given height was in the range of 10%. Single fluid full cone nozzles (opening angle  $60^\circ$  and  $120^\circ$ ) manufactured by Spraying Systems were chosen for the investigations. The spray droplet diameter into free environment is expected to be in the range of  $1000 \mu\text{m}$ . The liquid mass flux was set to 60 and 90 l/h respectively. For local measurements access inlets for needle probes are available at twelve positions from 7.5 below to 527.5 mm above the outlet of the spraying nozzle. The needle probes were inserted only from the site opposite to the feeding pipe.

## Measuring methods

### THERMOCOUPLES

First measurements were taken with K-type thermocouples manufactured by TC electronics with an outer diameter of 0.5 mm. In comparison measurements with thermocouples of 1.5 mm diameter deliver a reasonable signal with improved lifetime. In figure 3 the temperature for different radial positions  $r/R$  is given, whereas  $r/R=1$  means the riser wall.

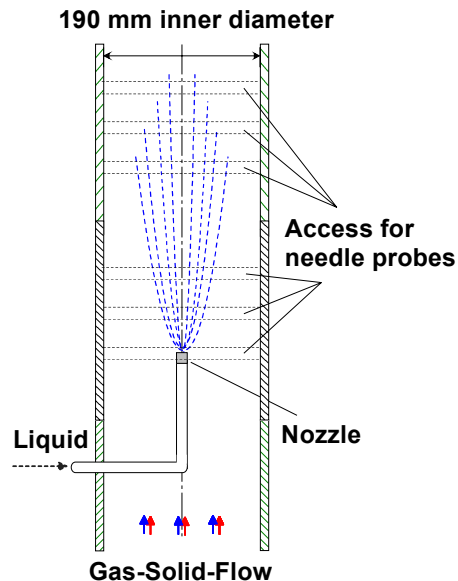

Figure 2: Injection geometry (axial)

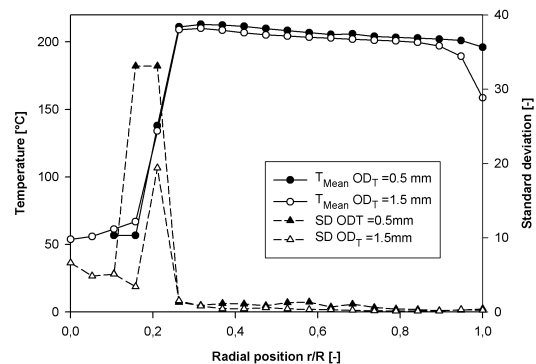

Figure 3: Influence of probe diameter distance to the nozzle  $z=120 \text{ mm}$

The outer diameter of the probe tip determines the response time of the thermocouple due to the increasing volume to be cooled or heated up by the

measured medium. The thicker the probe tip the longer the response time. Using the thicker thermocouple, this behavior leads to lower values of the standard deviation near the centre of the riser above the injection zone where the highest fluctuations are observed. The mean temperature taken from 2 seconds sample time (sampling rate 1 kHz) however is barely affected.

### CAPACITANCE PROBES

Capacitance probes are frequently used to measure solid concentration and solid mass flux inside circulating fluidized beds (4). The utilized probe has a tip diameter of 0.5 mm. It protrudes about 5 mm from the probes main body with an outer diameter of 3 mm. This probe system has a capacitance measuring volume of approximately 5 mm in length and 3 mm in diameter which is influenced by the solids concentration in other words the mean dielectric constant of the measuring volume. The capacitance is converted into a voltage signal and by calibration measurements it is possible to relate a measured voltage to the solids concentration. The dielectric constant of water  $\epsilon_{\text{Water}}$  exceeds the value of solids by a multitude of 10 to 20. According to this difference, liquid water trespassing the measuring volume will lead to a significant higher signal change compared to trespassing solids.

### CONDUCTIVITY PROBES

The conductivity probe consists of a centre electrode of 0.5 mm diameter which is insulated to the outer 1.5 mm electrode by a ceramic tube. The pointed probe was connected to a direct current source of 12 Volt. The fall of voltage over a resistor was monitored by an oscilloscope.

### Radial spray profile

The radial temperature distribution and the related standard deviation SD for three different heights  $z$  above the injection level are depicted in figure 4. The solid mass flux density was  $420 \text{ kg/m}^2\text{s}$  and the superficial gas velocity  $U_G=10 \text{ m/s}$ .

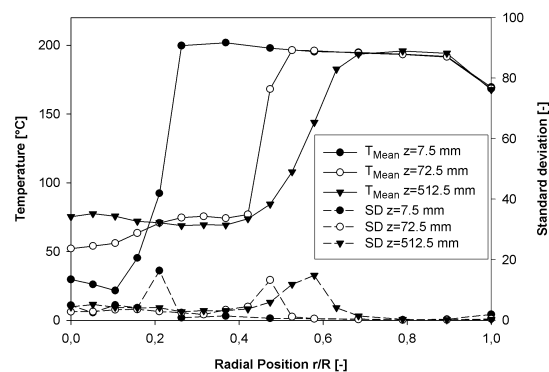

Figure 4: Spray criterion

According to this figure three distinctive regimes have been identified. The outer region near the wall of the circulating fluidized bed is not influenced by the evaporating liquid. Though, the insufficient thermal isolation leads to a temperature drop at the riser wall ( $r/R=1$ ). The inner region just above the evaporating spray shows a nearly homogeneous radial temperature distribution and minor fluctuations. Between the inner and outer region is a transition zone. The extent of the transition zone increases concurrent with distance to the nozzle. Within this transition zone the standard deviation of the temperature rises steeply to a maximum. This maximum was defined as the qualitative measure to identify the dimension of the spray region. In the case of very low fluctuations however, a second criterion was used. The radial extent of the

According to this figure three distinctive regimes have been identified. The outer region near the wall of the circulating fluidized bed is not influenced by the evaporating liquid. Though, the insufficient thermal isolation leads to a temperature drop at the riser wall ( $r/R=1$ ). The inner region just above the evaporating spray shows a nearly homogeneous radial temperature distribution and minor fluctuations. Between the inner and outer region is a transition zone. The extent of the transition zone increases concurrent with distance to the nozzle. Within this transition zone the standard deviation of the temperature rises steeply to a maximum. This maximum was defined as the qualitative measure to identify the dimension of the spray region. In the case of very low fluctuations however, a second criterion was used. The radial extent of the

temperature drop was taken into account and the mean radial position was calculated to define the axial spray borderline. The conductivity probe delivered a rather small fluctuation signal in the inner region and inside the transition zone. In the outer zone no fluctuations could be observed and the signal output dropped to 0 Volt. As a conclusion, no conductivity caused by moisture or liquid water was detected in the outer zone. This result supports the spray criterion postulated before. In addition, first measurements with capacitance probes were taken with a sampling rate of 5 kHz. The structure of the signals obtained bear relation to those of the measurements via thermocouples. The signal fluctuation of the capacitance probe delivers a similar maximum at the transition zone derived by the thermocouple measurements.

Within the spray region the needle probe probably is wetted or wet particles adhere to the surface and the temperature measured only refers to the cooling limit temperature. To separate some of the solids from the gas, two thermocouples were arranged in an axial distance of only 15 mm to each other. The first thermocouple in flow direction acts as a deflector for the second one. Figure 5 shows the radial temperature profiles for two distances  $z$  from the nozzle.

The lower diagram displays part of the radial temperature profile observed at the distance  $z=152.5$  mm and 15 mm above this position. Apparently, the profiles measured by the two thermocouples are in good agreement. However, in the upper diagram the temperature measured by the second thermocouple reveals to be significantly higher and even exceeds the boiling temperature of the injected water. Under these circumstances, there are two implications. On the one hand it is obvious that at least up from a distance of 447.5 mm to the nozzle vaporization of water occurs. On the other hand further experiments are necessary to interpret the measured temperature. Obviously, the shielding provided by the lower thermocouple leads to a higher measured temperature compared to that of the upper one. This indicates that the spray region consists of elements with different temperatures. The lower thermocouple delivers a mean temperature where cold elements are dominating. The shielding provided by the lower probe leads to a higher mean temperature because cold elements are separated from the gas-solid flow. Hence, the hot elements are dominating. Thermocouples with a reasonable lifetime for the given riser flow possess no adequate response time to separate trespassing elements of different temperature. The next step will be an improved probe design to

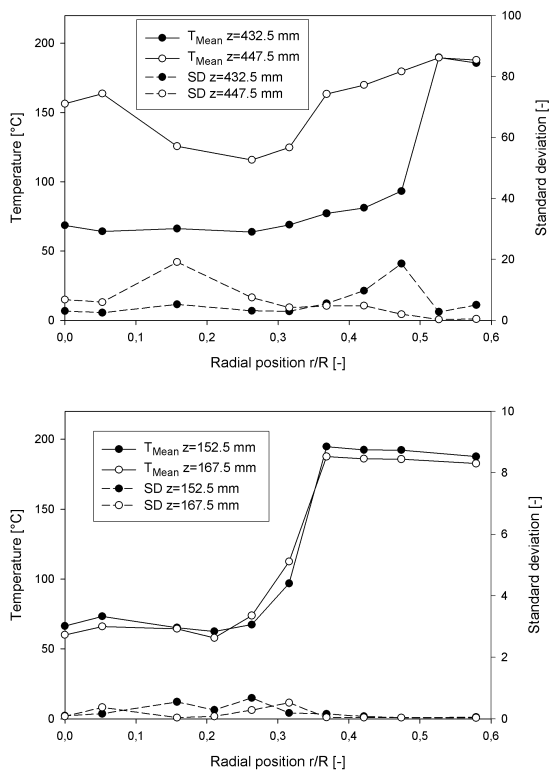

Figure 5: Shielding by consecutively arranged thermocouples

measure particularly the mean temperature of the gas phase. Also a deflector may be necessary to avoid adhesion of liquid or wet solids on the surface of the probe.

### Axial spray profile

The influence of different operating parameters on the spray development was investigated. Figure 6 depicts the axial spray outline for different operating parameters. The varied parameters include the spray cone opening angle ( $60^\circ$ ;  $120^\circ$ ), water volume flux (60; 90 l/h) and the superficial gas velocity  $U_G$  (10; 5 m/s). The change of water volume flux and gas velocity proves to be of minor influence on the spray region, all the more considering the fact that with a superficial gas velocity of  $U_G=5$  m/s the mass flux  $G_S$  dropped to  $240$  kg/m<sup>2</sup>s.

The spray opening angle has more impact particularly on the first half of the characterized spray zone, i.e. up to a distance of 150 mm from the nozzle, but has no apparent influence on the second half. To give an idea about the mass transfer into the spray region a simple enthalpy balance is used. In figure 7 the spray region is approximated by a cylinder.

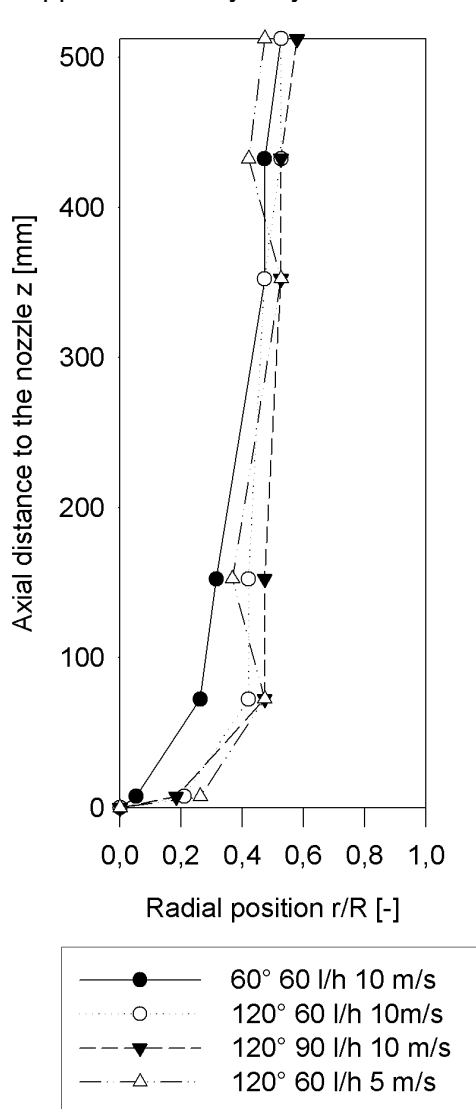

Figure 6: Axial spray development

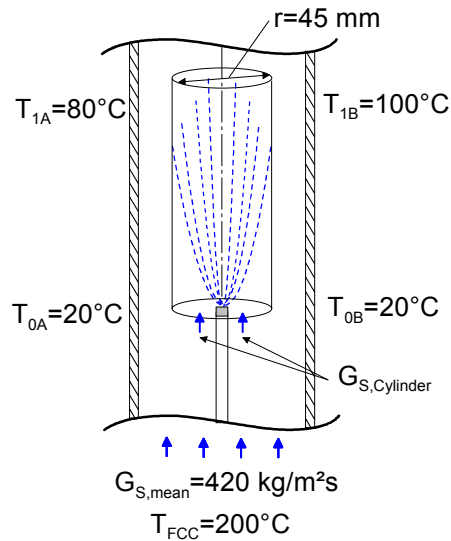

Figure 7: Enthalpy flux model

The enthalpy flux into the cylinder shall be mainly determined by the mass flux of hot solids entering the cylinder via the circular bottom area. Two cases are considered for following assumptions: solids enter the cylinder with the temperature  $T_{FCC}=200^\circ\text{C}$  and leaves the cylinder with the mean temperature of  $(T_1-T_2)/2$ . The left side of figure 7 represents the first case (A): the enthalpy demand is given only by the temperature increase of liquid water. No evaporation occurs. On the right side of figure 7 the second case is described (B): heating up the liquid to  $100^\circ\text{C}$  and

evaporating the injected water completely. For both cases the mass flux density at the circular bottom of the cylinder was calculated. The water injection of 60 l/h requires a mass flux density of  $G_{S,Cylinder,A}=6 \text{ kg/m}^2\text{s}$  and  $g_{S,Cylinder,B}=61 \text{ kg/m}^2\text{s}$ . Compared to the mean mass flux density of  $G_S=420 \text{ kg/m}^2\text{s}$  these values are significantly lower. For that reason two models are possible. First, the real mass flux into the cylinder is below the required value to vaporize the liquid. The spray borderline is merely penetrated and hot particles are repelled by vaporizing water. Second and more likely, not all of the solids entering the spray zone are wetted by the liquid. There are also hot particles in the spray region. However, the thermocouples are not able to determine their temperature. On this account the mixing of solids and liquid is estimated to be poor in the case of concurrent Liquid feed injection into a high-density riser.

### Conclusion

The injection of water into a high-density riser was studied at the temperature of 200°C. Three different radial regimes have been identified according to the temperature distribution and the corresponding standard deviation. The transition zone between outer and inner regime shows strong fluctuations which deliver a reasonable measure to identify the borderline of the spray zone. Additional qualitative measurements by capacitance and conductivity probes suggest this criterion as reasonable.

The axial extent of the spray region is mainly influenced by the spray cone opening angle. The wider the opening angle the greater is the angle between gas-solid-flow and the spray cone borderline. On this account further investigations require the modification of the injection geometry. The radial development did not admit the determination of the spray length within a distance of more than 500 mm away from the nozzle. Moreover, the radial extent of the spray remained almost fixed after a distance of 150 mm, i.e. inside the high-density riser only limited radial mixing of solid and liquid occurs. A simple enthalpy flux model was used to estimate the mass flux density into the spray zone which was approximated as a cylinder. The calculated mass flux density required was found to be much smaller than the mean mass flux density inside the riser. This is a secondary indication for low mixing intensity of solids, wet solids and liquid inside the high-density riser for concurrent liquid feed injection.

### Acknowledgement

Financial support of the experimental investigations by the Deutsche Forschungsgemeinschaft (DFG) is gratefully acknowledged.

### Notation

$G_S$	Solid mass flux density [ $\text{kg/m}^2\text{s}$ ]	$R$	riser radius [m]
$h$	height [m]	$SD$	Standard deviation [-]
$H$	riser height [m]	$T$	temperature [ $^{\circ}\text{C}$ ]
$OD_T$	Outer diameter of thermocouple [mm]	$U_G$	superficial gas velocity [m/s]
$r$	radius [m]	$z$	radial distance to nozzle [m]

	Greek letters	$\rho_s$	Solid density [kg/m <sup>3</sup> ]
$\varepsilon$	dielectric constant [-]		

### References

- (1) Chen, Y.-M., Williams, C.: *FCC Technology - recent advances and new challenges*; 8<sup>th</sup> Int. Conference on Circulating Fluidized Beds, Hangzhou, China, (2005), S. 26-40.
- (2) Bruhns, S.: *On the Mechanism of Liquid Injection into Fluidized Bed Reactors*; PhD Dissertation, Technische Universität Hamburg-Harburg, 2002.
- (3) Fan, L.-S.; Lau, R.; Zhu, C.; Vuong, K; Warsito, W; Wang, X; Liu, G.: *Evaporative liquid jets in gas-liquid-solid flow system*; Chemical Engineering Science 56 (2001), 5871–5891.
- (4) Hage, B., Werther, J., Narukawa, K. and Mori, S.: *Capacitance probe measurement technique for local particle volume concentration in circulating fluidized bed combustors*; J. Chem. Eng. Jpn. 4, pp.594-602 (1996).

