

## SCALE DEPOSITS IN POROUS MEDIA AND THEIR REMOVAL BY EDTA INJECTION

J. Moghadasi<sup>1,3</sup>, H. Müller-Steinhagen<sup>2\*</sup>, M. Jamialahmadi<sup>1</sup> and A. Sharif<sup>3</sup>

<sup>1</sup> Petroleum Engineering Department, Petroleum University, Ahwaz, IRAN

<sup>2</sup> Institute of Thermodynamics and Thermal Engineering, University of Stuttgart, Institute of Technical Thermodynamics, German Aerospace Centre (DLR),

D-70550, Stuttgart, GERMANY. E-Mail: [hms@itw.uni-stuttgart.de](mailto:hms@itw.uni-stuttgart.de)

<sup>3</sup> Chemical and Process Engineering Department, University of Surrey, Guildford, GU2 7XH, UK

### ABSTRACT

Formation damage has been observed in several oil reservoirs and production equipment in Iranian oil fields. Laboratory and field testing confirmed that the primary cause of damage was the build-up of calcium carbonate, calcium sulfate and strontium sulfate scale either in the perforation tunnels or in the formation sandstone nears the wellbore. Conventional acid treatments could dissolve this scale, but scale precipitation from the spent acid caused rapid productivity decline. A scale removal treatment with Na<sub>2</sub>H<sub>2</sub>EDTA has been developed that can effectively dissolve scale and chelate the dissolved metal ions. Chelation of the dissolved scale prevents scale re-precipitation. This study describes the results of an experimental and theoretical study on the removal of formation damage resulting from scale formation in porous media. An experimental investigation was undertaken to look into the possible causes of the injectivity loss in a typical Iranian oilfield. Sets of experimental investigations were undertaken with different objectives in mind. Glass and sand bead packs were used to test the experimental set up and to observe the general behaviour of scale formation and removal by ethylene diamine tetra acetic acid (EDTA) to determine its possible effects on the permeability of the porous medium.

### 1. Introduction

In recent years, scale removal techniques have become increasingly complex and the number of fluids and additives has continually grown. The purpose of this paper is to provide the field engineer with the fundamental understanding of the calcium sulfate removal procedures and the roles played in this process by different fluids and additives, so that a more cost-effective treatment can be planned.

The problem of calcium sulfate scale deposition has been recognised and reported by the oil and gas industry for many years in numerous publications [1-23]. The task of removing this scale has been essential

to maintaining operations and has been the inspiration for numerous innovative removal techniques, both mechanical and chemical. The mechanical techniques are very effective at removing calcium sulfate scale in the well bore but they do not adequately restore the permeability that has been lost in producing horizons [24, 25]. Chemical removal techniques are much better suited for restoring reservoir productivity.

Much of the information and knowledge about these chemical removal techniques has been at the research level and has not been totally assimilated into field practice. The oilfield chemical industry has historically used terminology that represents the physical appearance of a chemical reaction with calcium sulfate scale. While being very descriptive, these terms (converter, decomposer, disintegrator, and dissolver) have not quantified the amount of scale that can be removed in practice. The purpose of this paper is to present the data accumulated about these chemicals so that the effectiveness of scale removal techniques can be estimated.

#### 1.1 Scale problems in oil fields

Scale formation in surface and subsurface oil and gas production equipment has been recognised to be a major operational problem. It has been also recognised as a major cause of formation damage either in injection or producing wells. Scale contributes to equipment wear and corrosion and flow restriction, thus resulting in a decrease in oil and gas production. Experience in the oil industry has indicated that many oil wells have suffered flow restriction because of scale deposition within the oil-producing formation matrix and the downhole equipment, generally in primary, secondary and tertiary oil recovery operation as well as in the surface production equipment.

Costs due to scale formation in oil fields are high, because of drastic oil and gas production decline, frequent pulling of down-hole equipment for replacement, re-perforation of the producing intervals, re-drilling of the plugged oil wells, stimulation of the plugged oil-bearing formation, and other remedial

work-overs. As scale deposits around the wellbore, the porous media of formation become plugged and may be rendered impermeable to any fluids. Many case histories [12, 14, 18-23, 26-42] of oil well scaling by calcium carbonate, calcium sulfate, strontium sulfate and barium sulfate have been reported. Problems pertaining to oil well scaling in North Sea fields have been reported [23] and are similar to cases in Russia where scale has severely plugged wells. Oilfield scale problems have occurred as a result of water flooding in Algeria, Indonesia in south Sumatra oilfields, Saudi oil fields and Egypt in El-Morgan oilfield [6] where calcium and strontium sulfate scales have been found in surface and subsurface production equipment.

Scale deposits sometimes limit or block oil and gas production by plugging the oil-producing formation matrix or fractures and perforated intervals [20, 21, 32, 33, 43]. Scale can also be deposited in tubing, casing flow-lines, heater treaters, tanks, and other production equipment and facilities.

## 1.2 Damage Mechanisms

Scale can occur at /or downstream of any point in the production system, at which supersaturation is generated. Supersaturation can be generated in single water by changing the pressure and temperature conditions or by mixing two incompatible waters. The most common oilfield scales deposited are calcium carbonate, calcium sulfate, strontium sulfate and barium sulfate. Calcium carbonate scale generally causes a sharp reduction in pressure such as that exists between the formation and the well bore and across any constriction in the production tubing, e.g. checks and safety valves. The reduction in pressure liberates CO<sub>2</sub> into the gas phase leaving a solution, which is supersaturated in calcium carbonate. The various forms of calcium sulfate scale, i.e. gypsum, anhydrate and hemi-hydrate, can be formed due to an increase in temperature. Figure 1 gives some indication about the changes that occur in different parts of an oilfield.

## 2. Type of scales in oil fields

The most common oil field scales are listed in Table 1, along with the primary variables, which affect their solubility.

### 2.1 The nature of calcium sulfate scale

#### 2.1.1 *Composition*

Calcium sulfate is a crystalline deposit that is very adherent to many surfaces. It is composed mainly of calcium and sulfate ions, but when deposited from complex polymetallic solutions can contain traces of many other ions. Calcium sulfate often co-precipitates with strontium sulfate, with which it can form an aqueous solution. Additionally, on precipitation from

oilfield fluids, it may contain small amounts of wax, rust and silt.

#### 2.1.2 *Types of Calcium Sulfate*

Calcium sulphate precipitation is complicated by the fact that it can crystallise from aqueous solution in three forms: gypsum (CaSO<sub>4</sub>·2H<sub>2</sub>O), hemihydrate (CaSO<sub>4</sub>·½H<sub>2</sub>O), and anhydrate (CaSO<sub>4</sub>). These compounds may be stable depending on temperature and ionic strength. The morphology of CaSO<sub>4</sub> scale has been studied by many investigators, including George and Nancollas et al. [27], Vetter et al. [38] and Dickson et al. [44].

#### 2.1.3 *Calcium Sulfate Solubility*

Solubility is defined as the limiting amount of a solute, which can be dissolved in a solvent under a given set of physical conditions. The chemical species of interest to scale formation are present in aqueous solutions as ions. Certain combinations of these ions lead to compounds, which have low solubility. Once this capacity or solubility is exceeded the compounds precipitate from solution as solids. Therefore, precipitation of solid materials, which may form scale, will occur if:

- the water contains ions, which are capable of forming compounds of limited solubility.
- there is a change in the physical conditions or water composition, lowering the solubility.

Factors that affect scale precipitation, deposition and crystal growth can be summarised as: Supersaturation, temperature, pressure, ionic strength, evaporation, agitation, contact time and pH. Harberg et al. [7] investigated the effect of brine ion concentration, temperature and pressure on gypsum precipitation.

*Effect of temperature and pressure:* Landolt-Bornstein [13] shows the effect of temperature on solubility of calcium sulfate. The solubility of all calcium sulphate forms increases with temperature up to about 40 °C, and then decreases with temperature. Above 40°C, anhydrite becomes less soluble in water than gypsum, so it could reasonably be expected that anhydrite might be the predominant form of calcium sulfate in deeper, hotter wells. Actually, the temperature at which the scale changes form from gypsum to anhydrite or hemihydrate is a function of many factors including pressure dissolved salt content, flow conditions, and the rate at which different forms of calcium sulfate can precipitate out from water solution. Predicting which form of calcium sulfate will precipitate under a given set of conditions is very difficult. Even though an anhydrite precipitate might be expected above 40°C in preference to gypsum due to its lower solubility, gypsum may be found at temperatures up to 100°C. It is often difficult to precipitate anhydrite directly from solution, but, with the passage of time, gypsum can dehydrate to form anhydrite. Above 100°C, anhydrite

will precipitate out directly in a stirred or flowing system. If the system is quiescent the hemihydrate solubility becomes limiting. Conversion of hemihydrate to anhydrite could be expected to occur with time.

Dickson et al. [44] showed the effect of pressure and temperature on anhydrite solubility. The solubility of calcium sulfate in water increases with pressure. This increase in solubility is due to the fact that when the scale is dissolved in water, there is a decrease in the total volume of the system.

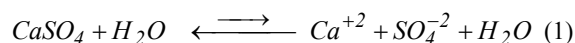

Pressure drop can be a major cause of calcium sulfate scale in producing wells and near the wellbore can create scale back in the formation as well as in the piping. Under downhole conditions, anhydrite or gypsum deposition is caused mainly by pressure drop, which has a stronger effect than temperature.

Under downhole conditions, anhydrite or gypsum deposition is caused mainly by pressure drop, which has a stronger effect than temperature.

Effects of agitation and vaporization: Agitation and vaporisation can increase scale production. The evaporation of water may cause supersaturated conditions, which lead to (accelerated) precipitation of calcium sulfate. Figure 1 gives some indication of which changes occur at which part of an oilfield.

Effect of ionic strength: Ionic strength is defined as:

$$I = \frac{1}{2} \sum C_i Z_i^2 \quad (2)$$

The solubility of calcium sulfate is strongly affected by the presence and concentration of other ions in the system. The effect of ionic strength is shown in Fig. 2 [45].

Effect of pH on crystal growth: Schierholtz [46] investigated the unseeded crystallisation of calcium sulfate dihydrate and followed the change in calcium concentration during the initial induction periods and subsequent growth at pH values ranging from 4.5 to 6.6. Within this range, the pseudo first order rate constant decreased by a factor of three. It was concluded that nucleation of calcium sulfate dihydrate is affected by pH. Austin et al. [2] studied the spontaneous precipitation of calcium sulfate phase from simulated seawater in the temperature range of 125 to 150°C at pH 2.3 to 8. Under these conditions, the hemihydrate phase precipitated first and there was a relatively slow transformation to the anhydrite phase, the rate of which was increasing with temperature.

## 2.2 The nature of calcium carbonate scale

Calcium carbonate scale is frequently encountered in oil field operations. Since Calcite is the most stable crystalline form of calcium carbonate under oil field circumstances, it is much more common than the other forms, i.e. Aragonite and Vaterite. Pure calcium carbonate crystals are relatively large, but co-precipitation with other impurities leads to finely divided crystals, resulting in a more homogeneous appearance of the scale. Deposition of CaCO<sub>3</sub> scale or sludge results from precipitation of calcium carbonate according to the following equation:

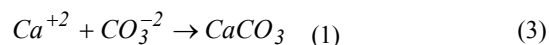

As it will be seen later, calcium carbonate scale can also be formed by combination of calcium and bicarbonate ions, and this reaction is the major cause of calcium carbonate scale deposition in oilfield operations. This is because, at the pH values found in most injection waters, only a small percentage of the bicarbonate ions dissociates into H<sup>+</sup> and CO<sub>3</sub><sup>-2</sup> (see Fig. 3. [31]).

### 2.2.1 Calcium carbonate solubility

Effect of carbon dioxide partial pressure: As opposed to most sulfate scales, the prediction of carbonate scales requires not only the consideration of pressures, temperatures and water composition, but also the knowledge on the chemical reactions within the brine and the CO<sub>2</sub> concentration in the gas phase. Most oilfield reservoirs contain carbonate mineral cements and carbon dioxide; therefore the formation water is normally saturated with calcium carbonate under reservoir conditions where the temperature can be as high as 200°C and the pressure up to 30 MPa. When carbon dioxide comes in contact with water, it dissolves and forms carbonic acid according to equation (4). The carbonic acid ionises to form hydrogen ions and bicarbonate ions. The ionisation of carbonic acid is illustrated by the following equations:

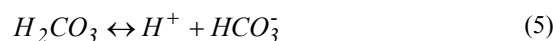
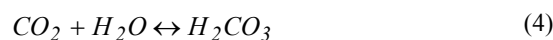

Since the second ionisation constant of carbonic acid is much smaller than the first ionisation constant, bicarbonate ions vastly outnumber the number of carbonate ions present under normal circumstances. It is believed that dissolved calcium carbonate does not exist in solution as calcium ions and carbonate ions, but as calcium ions and bicarbonate ions. Thus, the precipitation of calcium carbonate can be expressed by the following equation:

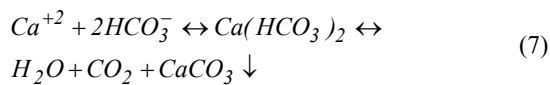

Applying LeChatelier's principle, we see that by increasing the concentration of carbon dioxide more calcium bicarbonate is formed. A decrease in carbon dioxide content in this system at equilibrium would result in the formation of calcium carbonate. Therefore, it can be seen that the solubility of calcium carbonate is greatly influenced by the carbon dioxide content of the water. The amount of CO<sub>2</sub> that will dissolve in water is proportional to the partial pressure of CO<sub>2</sub> in the gas over the water, which is the product of mole fraction of CO<sub>2</sub> in the gas phase and total pressure of the system. Hence, if either the system pressure or the percentage of CO<sub>2</sub> in the gas were to increase, the amount of CO<sub>2</sub> dissolved in the water would also increase. Figs. 4 and 5 illustrate the effect of CO<sub>2</sub> partial pressure on the pH of water containing little or no dissolved minerals and on the solubility of CaCO<sub>3</sub> in pure water, see reference [46]. These data illustrate that CaCO<sub>3</sub> solubility increases with increased CO<sub>2</sub> partial pressure. This effect becomes less pronounced as the temperature increases. The reverse of this effect is one of the major causes of CaCO<sub>3</sub> scale deposition: at any point in the system where a pressure drop occurs, the partial pressure of CO<sub>2</sub> in the gas phase decreases, CO<sub>2</sub> comes out of solution, and the pH of the water rises. This shifts reaction equation (7) to the right and may cause CaCO<sub>3</sub> precipitation.

Effect of total pressure: The solubility of calcium carbonate in a two-phase system increases with increased pressure for two reasons:

- increased pressure increases the partial pressure of CO<sub>2</sub> and increases the solubility of CaCO<sub>3</sub> in water as previously explained.
- increased pressure also increases the solubility due to thermodynamic considerations, as has been discussed for the case of calcium sulfate.

Effect of pH: The amount of CO<sub>2</sub> present in the water affects the pH of the water and the solubility of calcium carbonate. However it really does not matter what causes the acidity or alkalinity of the water. The lower the pH, the less likely is CaCO<sub>3</sub> precipitation. Conversely, the higher the pH, the more likely it is for precipitation to occur.

Effect of temperature: Contrary to the behaviour of most solutions, calcium carbonate becomes less soluble as temperature increases, i.e. the hotter the water the more likely is CaCO<sub>3</sub> precipitation. Therefore, water, which is non-scaling at the surface, may lead to scale formation in the injection well if the downhole temperature is sufficiently high. Plummer and Busenberg [47] show the general behaviour of CaCO<sub>3</sub> solubility as a function of temperature.

Effect of dissolved salts: Calcium carbonate solubility increases as the dissolved salt content of the water increases. Actually, the higher the total dissolved solids (not counting calcium or carbonate ions), the greater is the solubility of CaCO<sub>3</sub> in the water and the lower the scaling tendency, up to a maximum of about 200 g/l total dissolved solids.

### 2.3 Prevention of Scale Formation

The problem of preventing scale deposition has become increasingly important in recent years due to the increasing use of water flooding as a means of secondary oil recovery. Many methods have been proposed for removing or preventing scale deposition. Several chemical treatment methods have been effective, but there are many ineffective scale-removal agents and inhibitors still on the market today.

In many cases, scale control must begin with a program of inhibition since some inorganic scales are difficult – or even impossible – to remove by chemical treatment once they form. These scales, usually containing Barium or Strontium, can be prevented from forming by proper use of inhibitors. Fortunately, most scales occurring in producing formation are calcium sulfate or calcium carbonate. Two techniques have been used to place inhibitors into the formation. One technique involves placing slowly-water-soluble polyphosphate crystals in the formation by hydraulic fracturing. The polyphosphate limits the choice of fracturing fluid since it is sensitive to acid or heavy brine and reverts to inactive calcium orthophosphate. Liquid phosphonate inhibitors also have been placed during fracturing operations with the expectation that they will leak off and adsorb to the rock matrix.

Using liquid inhibitors in fracturing treatments will prevent scale deposition, but this is a comparatively expensive method of replacing inhibitor unless a fracture job is already planned for remedial stimulation. The second placement method is a matrix squeeze technique in which liquid inhibitors are injected into the formation at sub-fracturing pressures. This method is becoming increasingly popular because it is frequently undesirable to fracture the formation in a water flooding operation. In addition, this technique is cheaper than fracturing. There are many chemicals that will prevent scale deposition. However, most will not remain in the formation long enough, to make them economically feasible as inhibitors.

### 2.4 Conventional Methods for Scale Removal

Scale can be classified by methods of removal. Since chemically inert scales are insoluble in other chemicals, mechanical methods must be used to remove this kind of deposit. Chemically reactive scales may be classified as: water soluble, acid soluble and soluble in chemicals other than water or acid.

*Water soluble scales* are mainly sodium chloride, which can be readily dissolved with relatively fresh water. Acid should not be used to remove NaCl scale. Newly formed gypsum scale is porous and it may be dissolved by circulating water containing about 55000 mg/l NaCl past the scale. At 37°C, this brine will dissolve three times as much gypsum as fresh water.

*Acid soluble scales* are the most prevalent of all scale compounds. For example, calcium carbonate is acid soluble. HCl or acetic acid can be used to remove calcium carbonate; formic acid and sulfamic acid have also been used. Iron carbonate, iron sulfide, and iron oxide (Fe<sub>2</sub>O<sub>3</sub>) are also acid soluble. HCl with sequestering agent may be used to remove iron scales (15% HCl + acetic acid and citric acid may provide over 15 days of sequestering). A 10% solution of acetic acid may be used to remove iron scales without sequestering agent; however, acetic acid is much slower acting than HCl. The calculation of the required acid treatment is based on type and amount of scale.

Hydrochloric acid is not a good solvent for CaSO<sub>4</sub>. The maximum solubility of calcium sulfate in HCl is only 1.8 wt% at 25 °C and atmospheric pressure. Gypsum can be converted to acid soluble compounds by using converters such as (NH<sub>4</sub>)<sub>2</sub>CO<sub>3</sub>, Na<sub>2</sub>CO<sub>3</sub>, NaOH and KOH. The following reactions illustrate the mechanism of converter performance:

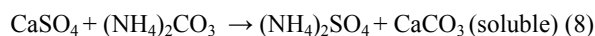

The calcium carbonate is then dissolved with HCl:



Scales are frequently coated with hydrocarbons, thus making it difficult for acid to contact and dissolve the scales. Surfactants can be added to all types of acid solutions to develop a better acid-to-scale contact. Surfactant selection for this use should be tested to determine that the surfactant will prevent acid-crude oil emulsion and will also leave rock surfaces water-wet.

Scale removal procedure for waxes, iron carbonate, and gypsum is as follows:

- Degrease with solvent such as kerosene or xylene plus a surfactant.
- Remove iron scales with a sequestered acid.
- Convert gypsum scale to CaCO<sub>3</sub>, or Ca(OH)<sub>2</sub>.
- Remove converted CaCO<sub>3</sub> scale with acid. Dissolve Ca(OH)<sub>2</sub> with water or weak acid.

### 2.5 CaSO<sub>4</sub> scale removal with EDTA

There are some commercially available chemicals such as EDTA and diethylene triamine penta acetic acid (DTPA), which can remove gypsum scale without conversion.

A chelating compound is formed when a metal cation combines with an anionic chelating agent. This chelating agent surrounds the metal with a ring-type structure which resembles a claw. Once chelated, the metal is bound to the chelating agent and will resist reactions with other compounds. Chelating agents will react with most metal cations but will not form a complex with a neutral metal until it has been ionized. Chelating agents are molecules which form stable bonds that are efficiently interconnected to use more reactive sites than its valence would indicate. A reactive site is any portion of a molecule that will form a polar charge (negative or positive), while the valence is defined as the measure of the combining power of a molecule. Ionized hydrogen is the standard with a positive valence of one. In the presence of calcium chelating agents such as EDTA, the rate of calcium sulphate dissolution is influenced predominantly by the rate of transport of reactants to the surface and the kinetics of the surface reactions at ambient temperature. Although the reactions are essentially irreversible because of the formation of a stable calcium complex, the reactions are influenced by the transport of products away from the surface. This influence is due to the blocking of surface sites involved in the dissolution. The dissolution mechanism is different from conventional acids in that hydrogen ions are not required. However, the rate of dissolution is enhanced at low pH as a result of the combined influence of hydrogen ion attack and chelation<sup>(8)</sup>. The rate of calcium sulphate dissolution varies considerably with pH and the type of chelating agent because of changes in the ionic form of the chelating agent<sup>(9)</sup> and the influence of hydrogen ion attack. In general, the rate of calcium sulphate dissolution increases as the number of hydrogen ions associated with the chelating agent increases. Based on the chelation behaviour of EDTA, one molecule of fully ionized EDTA (EDTA<sup>4-</sup>) is required to chelate each dissolved calcium ion (Eq. 12). Since the final objective of the scale removal treatment is to achieve both, dissolution and chelation, the desired chemical reaction is the sum of equations (11) and (12), i.e. equation (13).

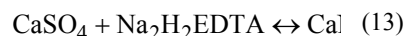
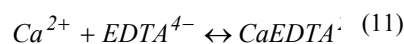
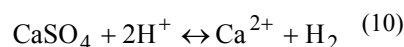

$$\Delta H = H_{\text{product}} - H_{\text{reactant}} = +213.82 \text{ Kcal / mol}$$

### 3. Experimental set-up and procedure

Experiments were carried out using a test rig, which is schematically shown in Fig. 6. The stainless steel tank is heated to approximately 50°C using four band heaters mounted on the outside. A small cooling water coil is installed inside the tank to allow accurate control of the liquid temperature in the tank. The thermocouple for determining the temperature inside the tank is connected to a controller for the band heater power output. Furthermore, a stirrer is placed inside the tank to agitate the liquid and to provide a uniform temperature. The peristaltic pump speed can be varied between 0.5-55 rpm, so that the liquid flow can be accurately adjusted. The maximum design pressure of the pump is 3 bars, which is achieved by using tubing with an internal diameter of 1.6 mm and a wall thickness of 1.6 mm. The tubing is made from Marprene II, a material that is resistant to water and mineral oil. For the scale formation experiments, a second, identical set of tank and peristaltic pump has been installed to mix the scale forming solution (i.e. one tank rich with  $\text{Ca}^{+2}$  and the other with  $\text{SO}_4^{-2}$  or  $\text{CO}_3^{-}$ ), which was drained after passing through the test section. The test section, which contains the porous medium, is made of stainless steel pipe with an internal diameter of 32 mm, a wall thickness of 5 mm and a total length of 580 mm. Spiral and longitudinal grooves to accommodate heating wire and thermocouples for measuring the wall temperature have been milled in the outside of the pipe. Bores to insert thermocouples for measuring the sand bed temperature, and opposite to them bores for pressure tapping, have been drilled at locations shown in Fig. 7. The cold-ended thermocoax resistance heating wire is fitted inside hemispherical grooves around the tube at a pitch of 8 mm, to give a heated area of 0.03488 m<sup>2</sup>. The power (maximum 2000 W) is controlled to maintain the wall temperature below the maximum operating temperature of around 200 °C. The test section has six pressure taps along its length, each of them connected to a separate pressure transducer. An additional perspex test section has been manufactured and installed in parallel for visual observation of the deposition mechanisms. All transducers have been connected to a computer-controlled data acquisition system for on-line monitoring and processing of the experimental results.

The packed bed is a direct method for studying deposition mechanisms from particle suspensions and salt solutions. A well defined granular material, which

## 4. Results and discussion

### 4.1 Clean bed experiments

Before carrying out any tests with solutions, it is first necessary to have adequate information regarding the flow mechanisms in a clean medium. When a fluid flows through a porous medium, the pressure drop, which develops along the bed in the direction of flow, is a function of system geometry, bed voidage and the physical properties of bed and fluid. The operating conditions can result in four distinct flow regimes [11]:

is usually made of spherical glass beads or wash sand, is packed in a column to form a porous bed with a fixed porosity. When the bed is fully packed, the porous medium fills the space between the two screens at the ends of the test section. The pore volume of the dry porous medium was then filled with liquid supplied from a burette to determine the porosity as the ratio of the required volume of liquid divided by the total volume of the bed. The same procedure was repeated several times for each medium and the mean value was taken to represent the porosity of the medium. The properties of the packing materials and of the investigated fluids are given in Table 2. Preliminary tests were performed to obtain the time after which the bed was stabilized: Distilled water was pumped through the bed for about one hour to obtain a homogenous condition. While all operational variables of the system were kept constant, pressure readings were taken at short time intervals until steady state was reached. This was usually achieved after about 20 minutes. The scale formation experiments were performed with aqueous solutions of  $\text{Na}_2\text{SO}_4$ ,  $\text{Ca}(\text{NO}_3)_2 \cdot 4\text{H}_2\text{O}$  and  $\text{Na}_2\text{CO}_3$ . The criteria for selecting these salts were based on the solubility of the salts and the valence of the respective ions. Each test liquid was mixed from two solutions of these salts, one rich in calcium ions and the other rich in sulfate or carbonate ions, which were kept separate until entering the porous medium. Mixing of calcium nitrate ( $\text{Ca}(\text{NO}_3)_2 \cdot 4\text{H}_2\text{O}$ ) and sodium sulfate ( $\text{Na}_2\text{SO}_4$ ) or sodium carbonate results in the precipitation of calcium sulfate or calcium carbonate in the porous medium. The range of salt concentrations used in this investigation is given in Table 3. Calcium nitrate and sodium sulfate or sodium carbonate solutions of predetermined concentrations were filled into the supply tanks. Distilled water was fed through the bed until the system reached a steady state at the desired temperature and flow velocity. Then the data acquisition system was switched on to record fluid flow rate, temperatures, and pressures. At this time the supply pumps were switched to the scale forming solutions for about 1600-1800 minutes then the supply pumps were switched to EDTA (ethylene diamine tetra acetic acid) solution and flooding continued for about 180-400 minutes. The range of investigated operating variables is also given in Table 3.

Darcy or creeping flow, inertial flow, unsteady laminar flow and chaotic (or turbulent) flow. In the Darcian region the pressure gradient is proportional to the flow rate and is mathematically expressed by

$$u = \frac{K}{\mu} \left( - \frac{\Delta p}{\Delta x} \right) \quad (14)$$

The coefficient K for single-phase flow depends only on the geometry of the porous medium. It is called the specific or absolute permeability of the medium; in the case of single-phase flow, this is abbreviated as permeability. The measurements of pressure drop as a

function of axial distance are presented in Fig. 8 for different media and liquid flow rates. As predicted by eq. (14), there is a linear relationship between the pressure drop and the axial distance in the direction of flow.

Knowing the viscosity of the liquid saturating the medium, the permeability of each medium can be calculated using the slope of the best-fit straight line through the data presented in Fig. 8 as the ratio of  $\mu u/K$  in equation (14). The calculated permeabilities are also given in Table 2.

#### 4.2 Scale formation experiments

The main objective of this part of the investigation is to study permeability reduction caused by calcium sulfate and calcium carbonate scale deposition in porous media. A wide range of flow velocities, bulk temperatures and fluid bulk concentrations are considered. During each run the pressure drop across the test section was recorded continuously. The pressure drop increased during the experiments only when a supersaturated solution was flowing through the test section. This confirms that the increase is caused by scale formation. The change of permeability and the pattern it follows are the most significant pieces of information to be gained from the experimental study. In the Figs. 9-12, the results for various flow rates, temperatures and concentrations are depicted, individually. Permeability decline caused by scale formation in the porous bed ranged from less than 30% to more than 90% of the initial permeability, depending on solution composition, initial permeability, temperature, flow rate and solution injection period. The pattern of permeability decline in a porous medium due to solution injection was characterized by a steep initial decline which gradually slowed down to a lower, but often still significant, constant damage rate. The initial steepness of these curves generally decreased with increasing distance from the point of mixing of the incompatible solutions.

At higher flow rates more calcium and sulfate ions will enter the porous medium over a given interval of time, hence providing more material for deposition (see Fig. 10). The permeability decline is more rapid at higher temperature, since the rate of precipitation and the supersaturation both increase with temperature (see Fig. 11).

Fig. 12 shows the variation in permeability decline with time for different concentrations. When the concentration of the solution (i.e. supersaturation) is increasing, plugging and hence permeability loss occur more rapidly.

#### 4.3 Experiments on scale removal by EDTA

The main objective of this part of the investigation is to study permeability increase caused by removal of calcium sulfate scale from porous media by EDTA. A wide range of flow rates, temperatures and concentrations are considered.

##### 4.3.1 *Effect of Flow Rate*

The inhibitor squeeze process is the normal oilfield method for avoiding problems with both sulfate and carbonate scales. The dynamics of the inhibitor return curves are governed principally by the fluid rock interactions in the adsorption/desorption type treatments that are normally carried out. To investigate the effect of flow rate on permeability increasing, a set of tests were performed, in which the temperature and concentration of EDTA solutions were kept constant while the flow rate was varied. These tests were carried out at a temperature of 80°C, 0.05 M EDTA concentration, and flow rates of 12.5, 25 and 50 cc/min.

Figs. 13 shows the variation of the permeability as a function of time. At higher flow rates more EDTA solution will enter the porous medium in a given interval of time, hence providing more material for removal of the precipitated CaSO<sub>4</sub>. However, the rise in permeability ratio was not linear with flow rate.

##### 4.3.2 *Effect of Concentration*

To investigate the effect of concentration on permeability increase, a set of tests were performed in which the temperature and flow rate of the EDTA solutions were kept constant while the concentration was varied. These tests were carried out at a temperature of 80°C, flow rates of 25 cc/min and 0.01, 0.05 and 0.1 M EDTA concentration. Fig. 14 shows the variation in permeability ratio with time for the different concentrations. When the concentration of the EDTA solution is increasing, removal of scale and hence permeability recovery, occurs more rapidly.

According to the principle of Le Chateliers, if the concentration of substance is increased, the equilibrium will shift in away in order to decrease the concentration of the substance that was added. For the present case this means that increasing the concentration of EDTA forces the equilibrium in the reaction eq. (13) to shift to the right and the rate of dissolution to increase.

##### 4.3.3 *Effect of Temperature*

Temperature has a significant influence on solubility and crystal growth of calcium sulfate. To study its effect on the permeability variation, a number of tests were carried out, where flow rate and concentration of the injected solution were kept constant and the temperature was varied. These tests were carried out at constant injection rates of 25 cc/min and 0.05 M EDTA concentration, and temperatures of 30, 50 and 80°C. Fig. 15 shows the variation of permeability with time for the different temperatures. The permeability rise is

more pronounced at higher temperature, since the rate of scale removal increases with temperature. This may also be explained by Le Chatelier's principle, taking into account the heat effect that accompanies the reaction given in eq. (13).

Hence, the forward reaction is endothermic and the reverse reaction is exothermic. In other words, the forward reaction absorbs heat, and the reverse reaction releases heat. If the temperature of the system is raised, the position of the equilibrium will shift to the direction in which heat is absorbed. If the mixture is cooled, the position of the equilibrium will shift to the left, i.e. the direction in which heat is released.

### 5. Conclusions

- i) The main influencing factors on scale formation have been examined. Temperature change had a remarkable effect on the scaling rate. At higher temperatures, calcium sulfate deposition is increased because the solubility of calcium sulfate decreases with increasing temperature. This must have increased the rate of precipitation and consequently the permeability decline. It was observed that brines with a higher degree of supersaturation produced a more rapid decline in permeability. This was to be expected since increased supersaturation would result in a more

rapid rate of scale precipitation. As the flow rate was increased, the rate of permeability decline becomes more rapid. At higher flow rates more calcium and sulfate ions will pass through the porous medium over a given interval of time. The average supersaturation will therefore be greater, producing a higher rate of precipitation. This increased precipitation rate will produce a larger overall permeability decline.

- ii) A scale removal treatment consisting of flushing with a solution of  $\text{Na}_2\text{H}_2\text{EDTA}$  dissolved in water can effectively dissolve scale and chelate the dissolved metal ions to prevent scale precipitation.
- iii) Several operational parameters which may influence scale removal have been investigated. At higher temperatures scale removal and consequently permeability recovery are increased because of the increased solubility for  $\text{CaSO}_4$  of the EDTA solution. Similarly, increasing the concentration of the EDTA solution produced a more rapid increase in permeability, since increased concentration results in a more rapid rate of scale dissolution. At higher flow rates EDTA can chelate the metal ions more effectively, and hence the original permeability is restored more rapidly.

### Nomenclature

A	cross-sectional area, $\text{m}^2$
C	total amount of ionic species in solution, M
$C_s$	mass solid concentration, $\text{kg}/\text{m}^3$
$d_c$	test section diameter, m
$d_p$	particle diameter, $\mu\text{m}$
$D_p$	pressure drop, $\text{N}/\text{m}^2$
$D_p/dx$	pressure gradient in x direction, $\text{N}/\text{m}^3$
EDTA	ethylene diamine tetra acetic acid
I	ionic strength, mole
K	permeability, $\text{m}^2$
M	flux of mass deposited, $\text{kg}/\text{m}^2/\text{s}$
P	pressure, $\text{N}/\text{m}^2$
$\Delta p/l$	pressure gradient, $\text{Pa}/\text{m}$
Q	volumetric flow rate, $\text{m}^3/\text{s}$
T	temperature, $^\circ\text{C}$ , $\text{K}^\circ$
T	time, min
U	Superficial velocity of flowing phase through porous medium, $\text{m}/\text{s}$
X	distance from inlet face of test section or core, m

### Greek Symbols

$\phi$	Porosity
$\mu$	fluid viscosity, $\text{kg}/\text{m}\cdot\text{s}$
$\Delta$	Gradient

### Subscripts

i	initial or inlet
---	------------------

l	Liquid
L	Length
m	matrix, mean and medium
PV	pore volume
sph	Sphere
SPE	Society of Petroleum Engineer
T	tube, pore
TC	Thermocouple
Superscripts	
$^\circ$	Degree

## References

1. Atkinson, G., Raju, K. and Howell R.W.: "The Thermodynamics of Scale Prediction," paper No. 21021, presented at the SPE International Symposium on Oilfield Chemistry, Anaheim, CA, 1991.
2. Austin, A.E., Miller, J.F. et al.: "Precipitation of Calcium Sulfate from Sea Water at High Temperature," *Desalination*, Vol. 16, pp.331-339, 1975.
3. Bezmer, C. and Bauer, K.A.: "Prevention of Carbonate Scale Deposition- A Well Packing Technique with Controlled Solubility Phosphates," *JPT*, Vol. 246, pp. 505-14, 1969.
4. Blout, C.W. and Dickson, F.W.: "Gypsum-Anhydrite Equilibrium in Systems  $\text{CaSO}_4$  and  $\text{CaSO}_4\text{-NaCl-H}_2\text{O}$ ," *Amer. Min.*, Vol. 58, pp. 1746, 1973.
5. Cowan, J.C. and Weintritt, D.J.: "Water Formed Scale Deposits," Gulf Publishing Co., pp. 586, Houston 1976.
6. El-Hattab, M.I.: "Gupco's Experiences with Treating Gulf of Squeeze Seawater for Water Flooding the El-Morgan Oil Field," *JPT*., pp. 1449-60, July 1982.
7. Harberg, T., Selm I. et al.: "Scale Formation in Reservoir and Production Equipment During Oil Recovery: An Equilibrium Model," *SPE production Engineering*, pp.75-84, Feb. 1992.
8. Khatib, Z.I.: "Prediction of Formation Damage Due to Suspended Solids: Modelling Approach of Filter Cake Build-up in Injectors," *SPE paper No. 28488*, SPE 69<sup>th</sup> Annual Technical Conference and Exhibition, New Orleans, La., Sep. 25-28, 1994.
9. Khillar, K.C. and Fogler, H.C.: "Colloidally Induced Fines Migration in Porous Media," *Reviews in Chemical Engineering*, Vol. 4(1 & 2), pp. 41-108, 1987.
10. Khillar, K.C. and Fogler, H.C.: "Colloidally and Hydrodynamically Induced Fines Migration in Porous Media," Chapter-19, in *Encyclopedia of Fluid Mechanics*, Vol. 10, Surface and Ground Water Flow Phenomena, Ed. N.P. Cheremisinoff, pp. 623-663, 1990
11. Krueger, R.F.: "An Overview of Formation Damage and Well Productivity in Oil Field Operation", *JPT*, pp. 131-152, Feb. 1986.
12. Krumine, P.H., Mayer, E.H. and Brock, G.E.: "Scale Formation During Alkaline Flooding," *JPT*, pp. 1466-1474, Aug. 1985.
13. Landolt-Börnstein: "Zahlenwerte und Funktionen," Vol. 2, Sec. B, Springer-Verlag, Berlin, 1985.
14. Lasetr, R.M., Grandner, T.R., and Glascock, F.M.: "Scale Deposits are Controlled Now with Liquid Inhibitors," *Oil and Gas J.*, pp. 88-63, Jan. 15, 1968.
15. Leon, J.A. and Scott, E.M.: "Characterization and Control of Formation Damage during Water Flooding at High Clay content Reservoir," Paper SPE 16234 Presented at the SPE Production Operation Symp., Oklahoma city, Mar. 8-10, 1987.
16. Lindlof, J.C. and Stoffer, K.G.: "A Case Study of Seawater Injection Incompatibility," *JPT.*, pp. 1256-62, July 1983.
17. Liu, S.T. and Nancollas, G.H.: "The Kinetics of Dissolution of Calcium Sulfate Dihydrate," *Journal of Inorg. Nucl. Chem.*, Vol. 33, pp. 2311, 1971.
18. Mitchell, R.W., Grist, D.M., and Boyle, M.T.: "Chemical Treatments Associated with North Sea Projects," *JPT*, pp. 904-12, 1980.
19. Moghadasi, J., Jamialahmadi, M., Müller-Steinhagen, H., Sharif, A., Ghalambor, A., Izadpanah, M.R. and Motaie, E.: "Scale Formation in Iranian Oil Reservoir and Production Equipment during Water Injection," Paper SPE 80406 Presented at the 5<sup>th</sup> International Oilfield Scale Symposium and Exhibition held in Aberdeen, UK, 29-30 January 2003.
20. Moghadasi, J., Jamialahmadi, M., Müller-Steinhagen, H., Sharif, A. and Izadpanah, M.R.: "Formation Damage in Iranian Oilfield," SPE paper No. 73781, Presented at SPE Formation Damage Control International Symposium and Exhibition, Lafayette, Louisiana, USA, 20-21 Feb., 2002.
21. Pang R. and Sharma, M.M.: "A Model for Predicting Injectivity Decline in Water Injection Wells," SPE paper No. 28489, SPE 69<sup>th</sup> Annual Conference and Exhibition, New Orleans, La., Sept. 25-28, 1994.
22. Shen, J. and Corsby, C.C.: "Insight Into Strontium and Calcium Sulfate Scaling Mechanisms in Oil Producing Wells," *JPT.*, pp. 1249-55, July 1983.
23. Todd, A.C. and Yuan, M.D.: "Prediction of Sulfate Scaling Tendency in Oilfield Operations," *SPE Production Engineering Journal*, pp. 63-72, Feb. 1991.
24. Crow, C.W.: "Evaluation of Agents for Preventing Precipitation of Ferric Hydroxide From Spent Treating Acid," *JPT*, pp. 691-695, Apr. 1985.
25. Cusack, F., Mc-Kinley, V.L., Lappin-Scott, H.M., Brown, D.R., Clementz, D.M., and Costerton, J.W.: "Diagnosis and Removal of Microbial/Fines Plugging in Water Injection Wells," Paper SPE 16907 Presented at the 62nd Annual Technical Conference and Exhibition of the SPE held in Dallas, TX September 27-30, 1987.
26. Nancollas, G.H. and Campbell, J.R.: "The Crystallisation and Dissolution of Strontium Sulfate in Aqueous Solution," *Journal of Physical Chemistry*, Vol. 23, No.6, pp. 1735-40, 1969.
27. Nancollas, G.H, Eralp, A.E and Gill, J.S.: "Kinetics of Growth of Calcium Sulfate Scale Formation: A Kinetic Approach," *SPE Journal*, pp. 133-138, 1978.
28. Nancollas, G.H. and Liu, S.T.: "Crystal Growth and Dissolution of Barium Sulfate," *SPE Journal*,

- pp. 509-16, 1975.
29. Nancollas, G.H. and Sawada, K.: "Formation of Scale Calcium Carbonate Polymorphs: the Influence of Magnesium Ion and Inhibitor," JPT, pp. 645-52, March 1982.
  30. Oddo, J.E and Tomson, M.B: " Why Scale Forms and How To Predict It," SPE Production and Facilities, Feb. 1997.
  31. Patton, C.C.: "Applied Water Technology," Campbell Petroleum Series, Norman, Oklahoma, 1968.
  32. Singley, J.E.: "Corrosion Prevention and Control in Water Treatment and Supply Systems," Noyes Publication, Houston, 1985.
  33. Thronton, S.D. and Lorenz, P.B.: "Role of Silicate and Aluminate Ions in the Reaction of Sodium Hydroxide with Reservoir Minerals", Paper SPE 16277 Presented at the SPE International Symposium on Oilfield Chemistry, San Antonio, TX, Feb. 4-6, 1987.
  34. Valone, W.F. and Skillern, K.R.: "An Improved Technique for Predicting the Severity of Calcium Carbonate," Proc. SPE of AIME International Oil Field and Geothermal Chem. Symp., Dallas, Paper No. 10549, pp. 11-32, 1982.
  35. Vetter, O.J.: "Oilfield Scale — Can We Handle It?," Journal of Petroleum Technology, pp.1402-08, Dec. 1972.
  36. Vetter, O.J. and Farone, W.A.: "Calcium Carbonate Scale in Oilfield Operations," SPE paper No. 16908 presented at the 62<sup>nd</sup> Annual Technical Conference and Exhibition held in Dallas, September 27-30, 1987.
  37. Vetter, O.J., Farone, W.A., Veith, E. and Lankford, S.: "Calcium Carbonate Scale Considerations: A Practical Approach," SPE paper No. 17009 presented in the International Symposium of Production Technology held in Lubbock, November 16-17, 1987.
  38. Vetter, O.J., Kandarpa, V. and Harvaka, A.: "Predication of the Scale Problems Due to Injection of Incompatible Waters", JPT, pp.273-284, Feb. 1982.
  39. Vitthal, S. and Sharma, M.M.: "Dynamics Model for Particle Deposition and Build up in Granular Media," Journal of Colloidal and Interface Science, 153, No. 2, pp. 314-336, Oct. 1992.
  40. Walsh, M.P., Rouse, B.A., Senol, N.N., Pope, G.A., and Lake, L.W.: "Chemical Interactions of Aluminium-Citrate Solutions with Formation Minerals," Paper SPE 11799 Presented at the International Symposium on Oilfield and Geothermal Chemistry held in Denver, CO, June 1-3, 1983.
  41. Wu, G.G.: "A PC-Windows-Based Program for Geostatistical Modelling Application," SPE Paper 28242 Presented at the SPE Petroleum Computer Conference held in Dallas, Texas, U.S.A., 31 July-3 August 1994.
  42. Yeboah, Y.D., Somuah, S.K. and Saeed, M.R.: "A New and Reliable Model for Predicting Oilfield Scale Formation," SPE paper No. 25166 presented at the SPE International Symposium on Oilfield Chemistry, New Orleans, Louisiana, 1993.
  43. Civan, F., Kapp Roy, M. Ohen Henry, A.: "Alteration of Permeability of Fine Particle Processes," Journal of Petroleum Science and Engineering, No. 3, pp. 65-79, 1989.
  44. Dickson, F.W., Blount, C.W. and Tunell, G.: "Use of Hydro-Thermal Solution Equipment to Determine the Solubility of Anhydrite in Waters from 100 °C to 275 °C and from 1 bar to 1000 bars Pressure," American Journal of Science, Vol. 261, 61, 1963.
  45. Carlberg, B.L and Mathews, R.R.: "Solubility of Calcium Sulfate in Brine," paper No. 4353 presented at the SPE Oilfield Chemistry Symposium, May 24-25, 1973.
  46. Schierholtz, O.J.: "The Crystallisation of Calcium Sulfate Dihydrate," Cd. J. Chem., Vol. 36, pp. 1057-63, 1950.
  47. Plummer, L.N. and Busenberg, E.: "The Solubilities of Calcite, Aragonite and Vaterite in CO<sub>2</sub>-H<sub>2</sub>O Solutions Between 0 and 90°C and an Evaluation of the Aqueous Model for the System CaCO<sub>3</sub>-CO<sub>2</sub>-H<sub>2</sub>O," Geochimica et Cosmochimica Acta, Vol. 46, pp. 1011-1040, 1982.
  48. Dybbs, A. and Edwards, R. V.: "Department of Fluid, Thermal and Aerospace Science report," FTAS/Tr (Case Western Reserve University) No. 75-117, Workshop on Heat and Mass Transfer in Porous Media (PB-252-387) (NTIS: Springfield, VA) pp. 228, 197

**Table 1 Most Common Oilfield Scales**

{PRIVATE}Name	Chemical Formula	Primary Variables
Calcium Carbonate	CaCO <sub>3</sub>	partial pressure of CO <sub>2</sub> , temperature, total dissolved salts, pH
Calcium Sulfate: Gypsum	CaSO <sub>4</sub> ·2H <sub>2</sub> O	temperature, total dissolved salts, pressure
Hemihydrate	CaSO <sub>4</sub> ·½H <sub>2</sub> O	
Anhydrite	CaSO <sub>4</sub>	
Barium Sulfate	BaSO <sub>4</sub>	temperature, pressure
Srtrontium Sulfate	SrSO <sub>4</sub>	temperature, pressure, total dissolved salts

**Table 2 Physical properties of packing material**

Packing material	Particle size range, μm	Mean particle diameter, μm	Porosity	Permeability, m <sup>2</sup>
Sand	180-250	192	0.3827	2.14E-11
	250-425	265	0.3830	6.03E-11
	400-500	410	0.3839	1.21E-10
	1000	1000	0.3853	7.27E-10
Glass	180-300	245	0.3787	4.41E-11
	250-425	338	0.3792	7.89E-11
	400-600	480	0.3804	1.59E-10
	1000	1000	0.3825	7.05E-10

**Table 3 Range of operating parameters in scale formation experiments**

Inlet temperature	50°C-80°C	
Flow rates	25 -100cm <sup>3</sup> /min	
System pressure	122 kPa	
Solution viscosity	0.7×10 <sup>-3</sup> -1.3×10 <sup>-3</sup> kg/m.s	
Solution concentration	Ca(NO <sub>3</sub> ) <sub>2</sub> ·4H <sub>2</sub> O	1.8 - 13.4 g/l
	Na <sub>2</sub> SO <sub>4</sub>	2.6 - 7.8 g/l
	Na <sub>2</sub> CO <sub>3</sub>	0.8 - 1.6 g/l
	CaSO <sub>4</sub>	2.5 - 7.5 g/l
	CaCO <sub>3</sub>	0.75 - 1.5 g/l
EDTA	(NCH <sub>2</sub> ) <sub>2</sub> - (CH <sub>2</sub> COOH) <sub>4</sub>	0.01 - 0.1 M

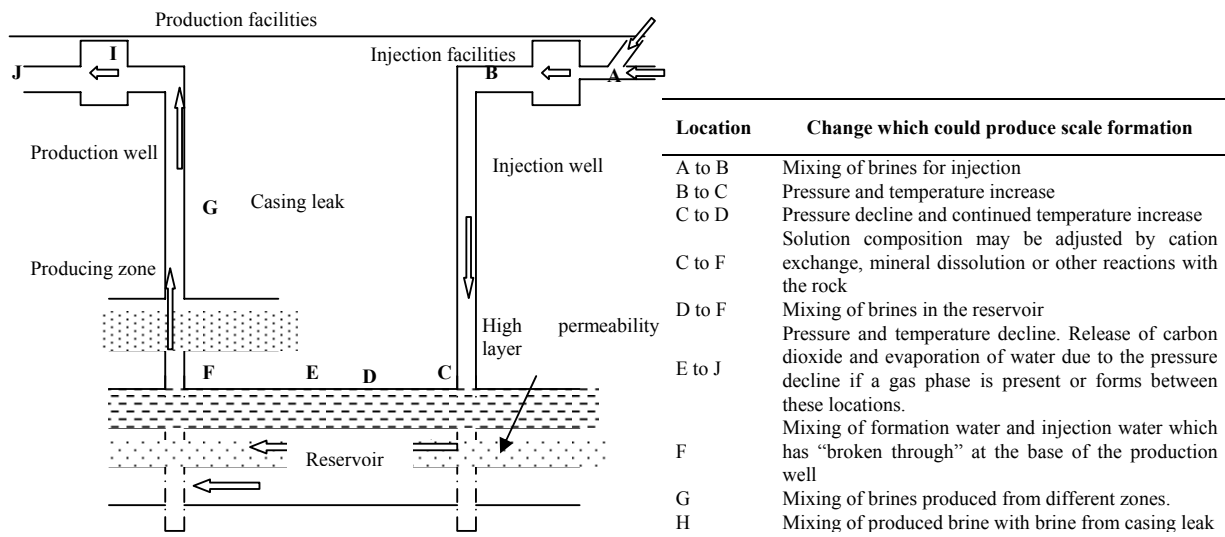

Fig. 1 Operational changes which may lead to scale formation at different locations

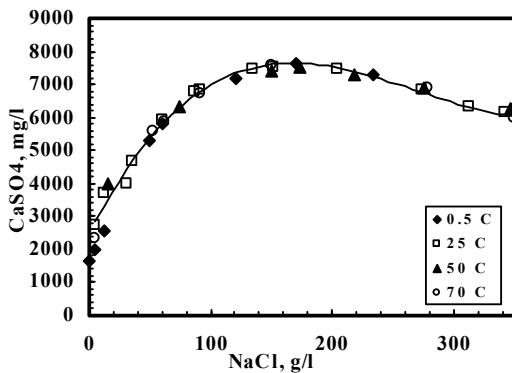

Fig. 2 Solubility of gypsum in NaCl brines at temperatures from 0 to 70 °C

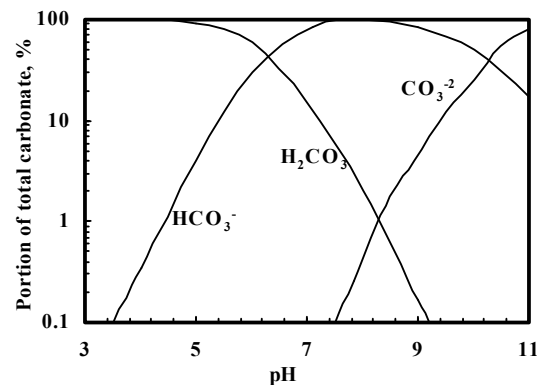

Fig. 3 Ionisation of carbonic acid at different pH values

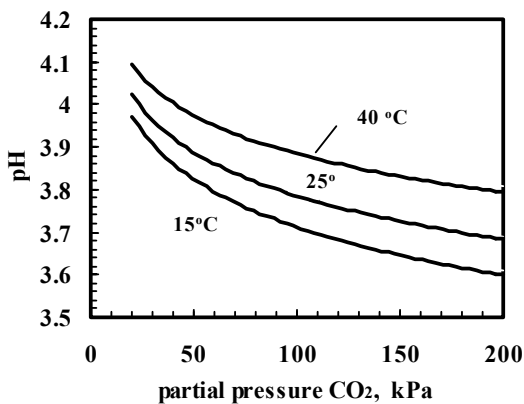

Fig. 4 Effect of CO<sub>2</sub> partial pressure on pH of water

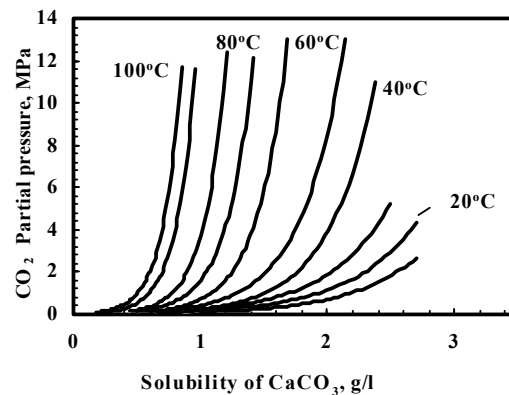

Fig. 5 Effect of CO<sub>2</sub> partial pressure on CaCO<sub>3</sub> solubility

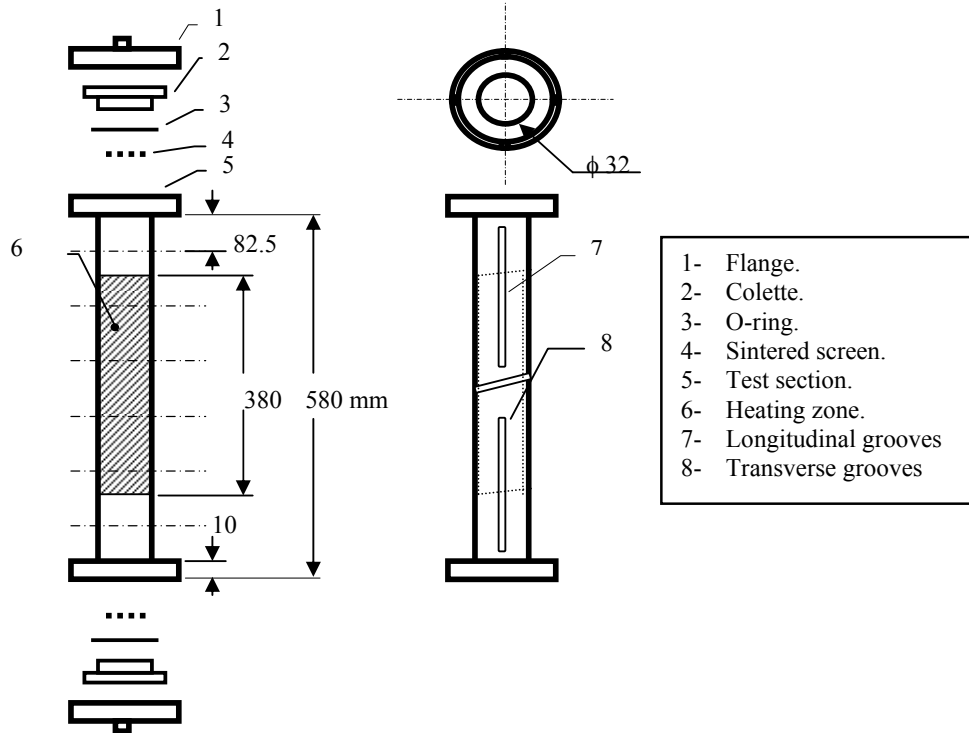
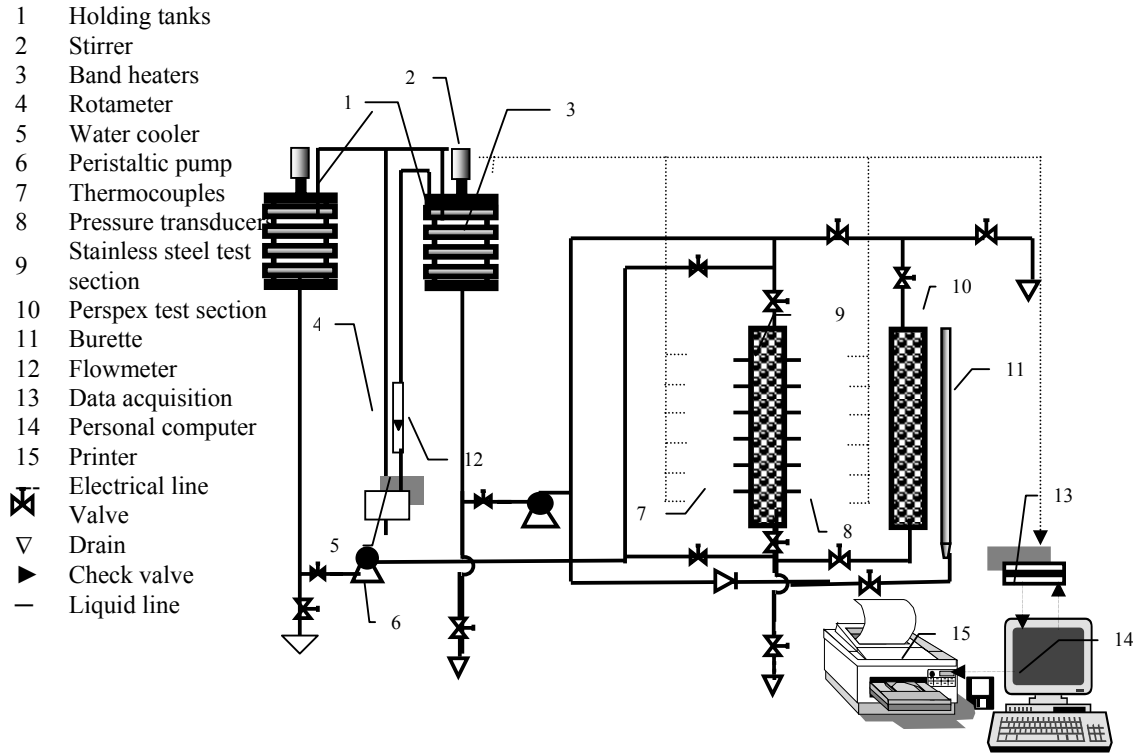

Fig. 7 Design details of the test section.

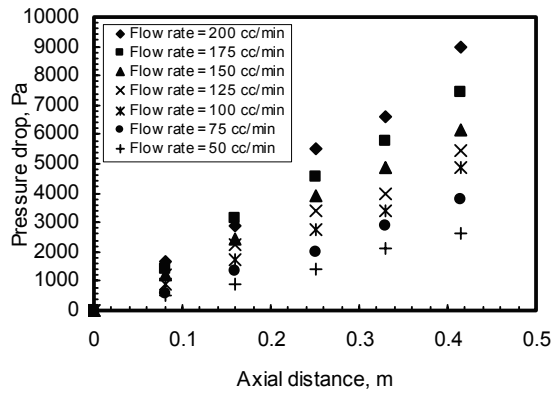

Fig. 8 Variation of pressure drop as a function of distance

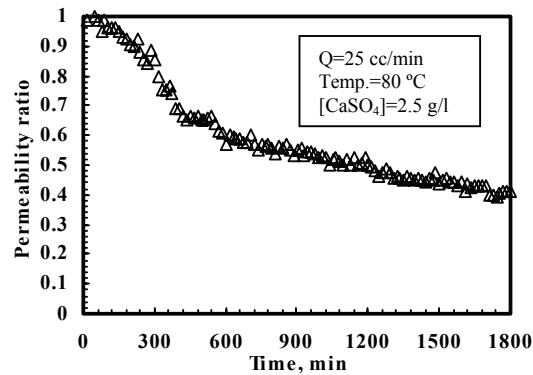

Fig. 9 Variation of permeability ratio as a function of time

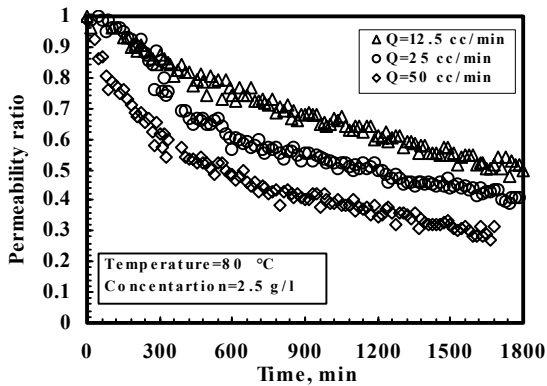

Fig. 10 Variation of permeability ratio as a function of time

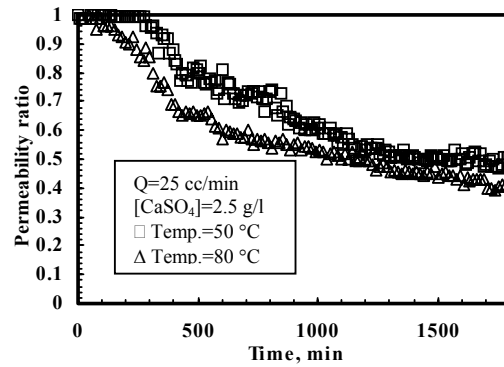

Fig. 11 Variation of permeability ratio as a function of time

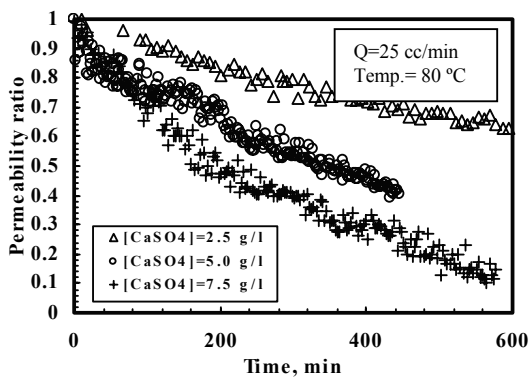

Fig. 12 Variation of permeability ratio as a function of time

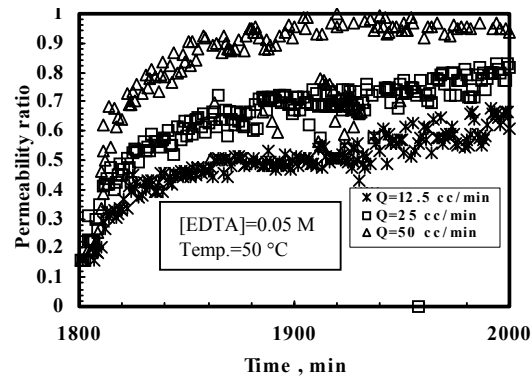

Fig. 13 Variation of permeability ratio as a function of time

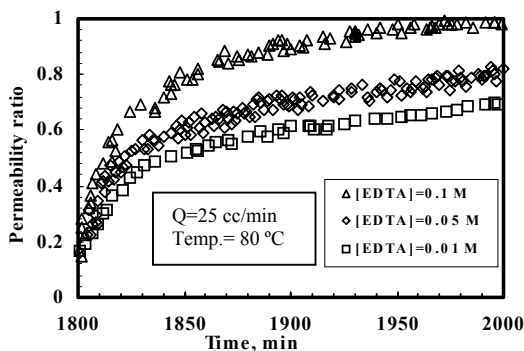

Fig. 14 Variation of permeability ratio as a function of time

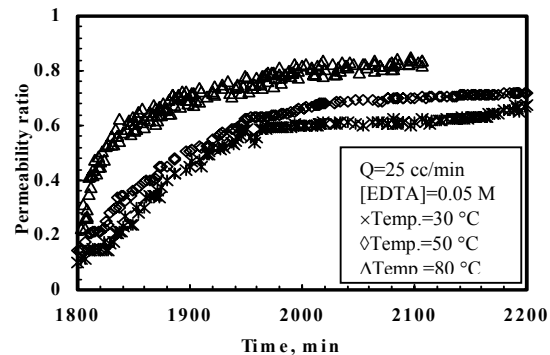

Fig. 15 Variation of permeability ratio as a function of time