

STUDY OF AN ORGANIC CRYSTALLIZATION FOULING PROBLEM

Hirofumi Inokuchi¹ Mitsutaka Nakamura¹ and Yoshio Koga²

¹ SSOT Equipment Design Group, Production Technology Department, Technology and Production Center, Mitsubishi Chemical Corporation

3-10,Ushiodori, Kurashiki, Okayama 712-8054 , Japan

e-mail: 1209887@cc.m-kagaku.co.jp (Hirofumi Inokuchi)

² Petrochemicals Research Center, Mitsubishi Chemical Corporation

17-1,Towada,Kamisu,Ibaragi 314-0102 ,Japan

e-mail : 4101029@cc.m-kagaku.co.jp (Y. Koga)

ABSTRACT

One of the aromatic compound plants in Mitsubishi Chemical Corporation has a heavy crystallization fouling problem. We have been studying the crystallization process using the shell and tube heat-exchanger. In order to solve our fouling problem of the heat exchanger, we developed the specified evaluation equipment (crystallization fouling simulator : CFS) which consists of a single tube heat-exchanger (Tube size: ID=10.3mm Length=500mm). The result of the modeling for describing the crystallization fouling rate and the countermeasure of the fouling problem are discussed in this work. It can be possible to describe the fouling rate as one equation which has two parameters, and the fouling rate of the industrial plant and the evaluation equipment agree with each other.

INTRODUCTION

One aromatic compound is one of the main petrochemical product in Mitsubishi Chemical Corporation. The process for this product has the crystallization system which has the shell and tube cooling heat-exchanger in the external circulating path of the crystallizer. The capacity of the heat-exchanger decreases over time because of the fouling growth on the pipe of the cooling heat exchanger. As a result, this plant has to have the spare heat exchanger for cleaning periodically. Switching the operation between the cooler of crystallizer and spare cooler for the cleaning is required every several hours and eventually the operation is stopped every several months because of the fouling growth in spite of the periodic cleaning. Figure 1 shows the process flow diagram of the crystallizer of the aromatic compound. In order to solve the fouling problem in the heat exchanger, we developed the specified evaluation equipment: CFS consists of a single tube heat-exchanger and study of establishing the model to estimate the fouling growth rate and find out the countermeasure of the fouling problem.

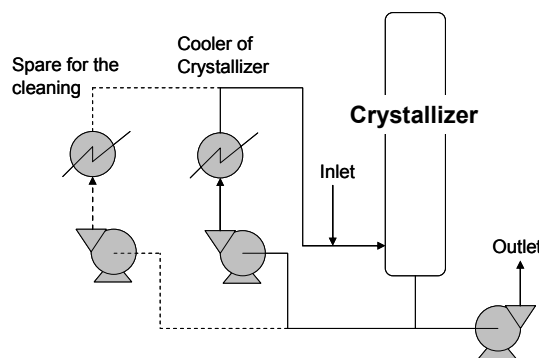

Figure1. Flow diagram of the Crystallizer of the aromatic compound

EXPERIMENTAL METHOD

Figure 2 shows the flow diagram of the single tube heat-exchanger unit. The slurry is re-circulated from the tank through the inside of the test cooler (Tube size: ID=10.3mm Length=500mm) and the downstream heater for recovery of temperature. Table 1 shows the specifications of the test cooler of CFS. Flow rate and inlet and outlet temperature can be measured in the slurry and the coolant line every one second, and the fouling rate is estimated every second.

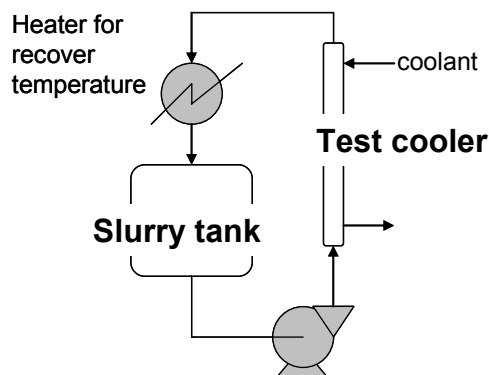

Figure2. Flow diagram of the crystallization fouling simulator (CFS)

Table1. Specifications of the CFS

Tube ID	10.3mm
Tube OD	12.7mm
Tube length	500mm
Tube material	SUS316
Tube roughness	Ra 2.1micro meter
Volume of the slurry tank	8 liters
Capacity of heat removal	20000kcal/hr/m ²
Velocity range of process	0 - 1.2m/s
Temperature of process	20 - 150 degC
Mass rate range of coolant	0 - 1.5 kg/min
Temperature of coolant	5 - 90 degC

APPROACH TO ANALYSIS OF DATA

The net fouling rate is considered as a balance of the formation and removal rate, as given by Kern and Seaton [1].

$$dm/dt = \rho_f (dx_f/dt) = \rho_f \lambda_f (dR_f/dt) = m_d - m_r \quad (1)$$

$$dR_f/dt = R_{fd} - R_{fr} \quad (2)$$

where

m = deposit mass/area (kg/m²)

x_f = deposit thickness (m)

R_f = fouling resistance (m² K/W)

m_d = formation term (kg/m² s)

m_r = removal term (kg/m² s)

R_{fd} = formation term (m² K/W s)

R_{fr} = removal term (m² K/W s)

Although various studies have been done on crystallization fouling, the formation term here was based on the Reitzer model [2], in which the deposition rate depends on the on the degree of supersaturation :

$$R_{fd} = K(C_b - C_s)^n \quad (3)$$

where C_b = bulk concentration, and C_s = surface concentration. For $n=1$ and linear temperature dependence of solubility,

$$R_{fd} = k_1(T_s - T_b) = k_2(q/h) \quad (4)$$

where q = heat flux (Q/A) (W/m²), h = heat transfer coefficient, and k_1 and k_2 are constants.

The Kern-Seaton [1] removal term is used, where the removal rate varies as the products of wall shear stress τ , and deposit thickness.

$$R_{fr} = k_3 \tau x_f \quad (5)$$

Thus using Equation (2)

$$dR_f/dt = k_2(q/h) - k_3 \tau x_f \quad (6)$$

In addition, the present authors added the effect of the radial direction of the pipe, and determined Equation (7)

$$dR_f/dt = k_4((r_o/r_{xf})(q/h)) - k_5((r_o/r_{xf}) \tau x_f) \quad (7)$$

As h varies as $Re^{0.8}$, Eq'n (7) can be re-written as

$$dR_f/dt = k_6((r_o/r_{xf})(q/Re^{0.8})) - k_5((r_o/r_{xf}) \tau x_f) \quad (8)$$

Constants k_6 and k_5 can be determined from measured fouling rates, using the CFS, which can be operated under a wide range of conditions as shown in Table 1.

RESULT

Initially, an attempt was made to verify the effect of the removal term by using CFS. After keeping a low process temperature for five hours, the temperature of the coolant is set to the same temperature as the process. As a result, we can make the condition that has only the effect of shear force by the flowage without heat transfer. After keeping this condition more than one hour, operation is returned to the original condition (the temperature of coolant goes down) and the changing of the fouling rate dR_f/dt is obtained. Then dx_f/dt is calculated from Equation (1) and shown in Figure 3. As the result of this CFS experiment, we find that there is no change in the deposit thickness during the period of having only the effect of shear force by the flowage. Velocity range of the CFS is 0-1.2m/s. Figure 3 shows the effect of the removal term is zero in CFS at a low velocity such as 1.2m/s.

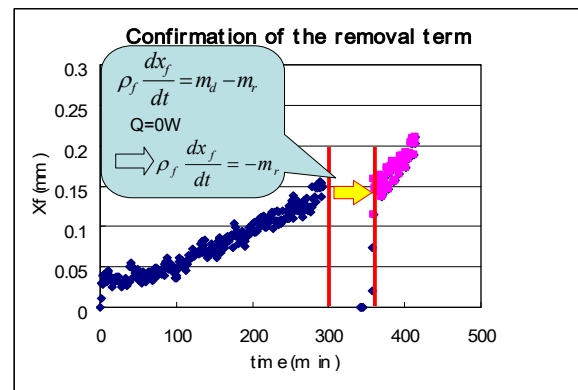

Figure3. Plot of x_f vs t to confirm removal term in CFS (Velocity 1.2m/s)

We assume that removal term of the actual plant is zero, as with the CFS and we compare the k_6 parameter between CFS and actual plant. Table 2 shows the operating conditions of the CFS and actual plant, and comparisons of the fouling rate of each. The k_6 parameter of the actual plant is almost the same as for the CFS.

Table 2 Comparison of the operation conditions between CFS and actual plant

		LV	Re	Q/A	dx/dt	dR _f /dt	K ₆
		m/s	-	W/m ²	m/s	m ² ·K/Ws	
EXP	start of run	2.3	10000	7100	4.90E-09	3.10E-08	2.5E-08
	end of run	2.2	9900	6400	4.40E-09	2.80E-08	
PLANT	start of run	1.2	2600	11000	1.03E-08	6.90E-08	3.0E-08
	end of run	1.2	2700	7400	8.33E-09	5.30E-08	

DISCUSSION

The k_6 parameter of the actual plant is almost the same as that of the CFS in spite of the large difference of line velocity between CFS and actual plant. This result is derived on an assumption that the removal term of the actual plant is zero. If this result is applicable for higher line velocity, increasing of the line velocity does not mitigate the fouling problem. Another ways, changing roughness of the tube for example, should be considered to solve the problem for this case.

In the future work, CFS should be improved to get higher line velocity than the actual plant, and then the result of this work could be confirmed

CONCLUSION

1. Removal term is zero at low velocity less than 1.2m/s.
2. The k_6 parameter of actual plant is almost same as the one of CFS.
3. The removal term of the actual plant could be zero.
4. Studying of countermeasure of the fouling problem could be available by using CFS.

ACKNOWLEDGEMENT

The authors would like to thank Professor A.P. Watkinson, UBC (The University of British Columbia) for his suggestions in the experiments and their interpretation.

NOMENCLATURE

x_f	deposit thickness (m)
m	deposit mass/area (kg / m ²)
m_d	formation term (kg/m ² s)
m_r	removal term (kg/m ² s)
R_f	fouling resistance (m ² K/W)
R_{fd}	formation term (m ² K/W s)
R_{fr}	removal term (m ² K/W s)
C_b	bulk concentration (kg/kg)

C_s	surface concentration (kg/kg)
T_s	surface temperature (°C)
T_b	bulk temperature (°C)
Q	heat duty (W)
A	surface area (m ²)
q	heat flux (W/m ²)
h	heat transfer coefficient (W/m ² K)
Re	Reynolds number (-)
r_o	radial of the tube outside (m)
r_{xf}	distance between fouling surface and center of the tube (m)
λ_f	deposit thermal conductivity (W/mK)
ρ_f	deposit density (kg/m ³)
τ	wall shear stress (N/m ²)

REFERENCES

- [1] "A Theoretical Analysis of Thermal Surface Fouling", D. Q. Kern, R. E. Seaton: British Chemical Engineering, May, 258-262, 1959.
- [2] "Rate of Scale Formation in Tubular Heat Exchangers", B. J. Reitzer: I&EC Process Design and Development, 3(4), October, 345-348, 1964.