

## INVESTIGATION OF FOULING PROCESS FOR CONVECTIVE HEAT TRANSFER IN AN ANNULAR DUCT

Y.C.Chen, Z.H.Quan and C.F.Ma

The Education Ministry Key Laboratory of Enhanced Heat Transfer and Energy Conservation,  
College of Environmental and Energy Engineering, Beijing University of Technology, Beijing 100022, China  
E-mail: chenyingchang@bjut.edu.cn

### ABSTRACT

Experimental and theoretical study is summarized of fouling process on heat transfer surface. An automatic monitoring system was set up to determine impact of fouling. Experiments were performed with artificial hard water as a working fluid at different conditions. Some important parameters including water temperature, wall temperature, flow velocity, water hardness and alkalinity were testified to make sure their influences on the fouling process on heat transfer surfaces. The ranges of water temperature, wall temperature, flow velocity and water hardness are between 20 ~ 50°C, 50 ~ 75°C, 0.5 ~ 2.0m/s, 200 ~ 1000mg/L (as CaCO<sub>3</sub>), respectively. All the experimental data were recorded continuously and the fouling resistances were calculated accordingly. Furthermore, an analysis was conducted to understand mechanism of fouling on heat transfer surface according a new physical model of fouling process. Good agreements can be observed between calculated results and experimental data.

### INTRODUCTION

Fouling has been recognized as a serious problem in heat exchangers because at least two questions associated with fouling occur including decreasing of heat transfer rate and increasing of flow resistance in heat transfer equipment. It was reported that total fouling related cost was more than 45 billion US dollars all over the world and more than 90 percents of heat transfer equipments were puzzled by fouling (Müller-Steinhagen,1995; Steinhagen et al.,1982). Scientists and engineers have paid much more attention to fouling in heat transfer equipment, but it is still an unsolved question in the field of heat transfer (Taborek, 1972).

Studies associated with fouling have been conducted and surveyed within monitoring experiments and predictive models of fouling (Somerscales and Knudsen, 1981; Somerscales, 1990; Yang et al., 2004). The most important aspect is the monitoring of fouling process, which is fundamental in fouling research. As the fouling relates to many characteristics such as fluid flow, heat and mass transfer, surface energy of material and chemical reactions, etc., it is very difficult to understand the mechanism of fouling on heat transfer surfaces. And much more

experimental data are required and collected to promote the fouling studies. Another aspect is theoretical analysis with physical model of fouling process. With enough experimental results some physical models may be established reasonably to predict actual fouling process. However, it is still insufficient in both storage of experimental data and construction of physical model at present. More work should be done in understanding mechanism of fouling in heat transfer equipment.

In order to promote research of mechanism of fouling process on heat transfer surface and developing reliable anti-fouling technology, present authors focus on fouling studies and provide their experimental results of fouling process and predictive results with a new physical fouling model (Xing et al., 2005; Xing, 2005, Quan et al., 2007).

### EXPERIMENTAL APPARATUS

An on-line monitoring apparatus of fouling resistance was developed for present experiments, in which fouling resistance can be measured on-line for different heat transfer surfaces. Fig.1 is a schematic diagram of the experimental set-up, which consists of heat transfer test section, hot water circulating loop, cooling water circulating loop, refrigerant water circulating loop, measuring & controlling device, and microscopic-imaging system (Charge Coupled Device, abbreviated to CCD). The heat transfer test section is composed of two concentric tubes: the inner one is a copper tube, and the outer one is a stainless steel tube with a short glass tube. The dimensions of the inner are 16.0mm×12.0mm×900mm ( $d_o \times d_i \times L$ ). And the dimensions of the outer are 25.0mm×22.0mm×800mm ( $d_o \times d_i \times L$ ). The hot water (pure water) flows inside the inner tube, whereas the cooling water (hard water as test liquid) moves in the annulus gap between the two tubes in the opposite direction of the hot water, thus forming a counter-flow heat exchanger. The scales deposit on the outside surface of the inner tube. The inlet temperature of the cooling water at test section maintains constant, fluctuating no more than  $\pm 0.2^\circ\text{C}$  and the hot water inlet temperature fluctuating no more than  $\pm 0.05^\circ\text{C}$ . In order to observe scale formation on the heat transfer surface online, a microscopic-imaging system was developed by our laboratory. In addition whole of the online

monitoring system of fouling resistance may run automatically and continually for long time.

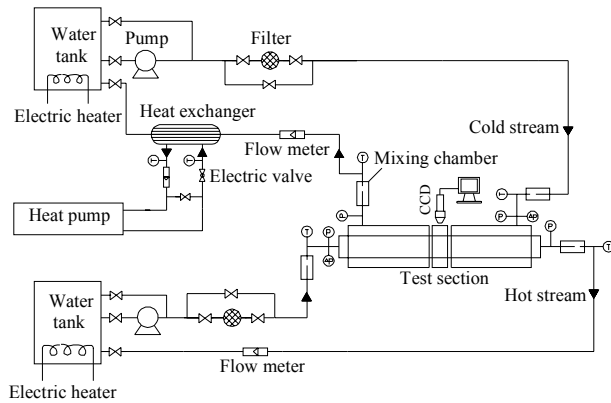

Fig.1 Schematic diagram of on-line monitoring apparatus of fouling resistance

Heat transfer performance was tested using smooth tube and with pure water as working fluid to determine reliability of the total apparatus. The turbulent flow heat transfer Nusselt number can be predicted by Gnielinski Equation and other heat transfer equations, and then were compared with the corresponding experimental measured values (Chen et al., 2001). As a result, the heat balance deviations of two sides' water are less than 10 percent (Fig.2). The predicted and measured Nusselt numbers are plotted against Reynolds number in Fig.3 and Fig.4 respectively for shell-side fluid (cooling water) and tube-side fluid (heating water). Measured Nusselt numbers agree well with the predicted values within deviations of 10%. Accordingly, the total system is reliable to be used to monitor the fouling process of heat transfer surface.

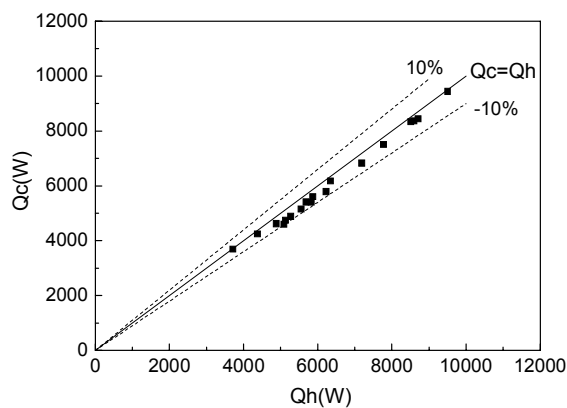

Fig.2 Heat balance of test section

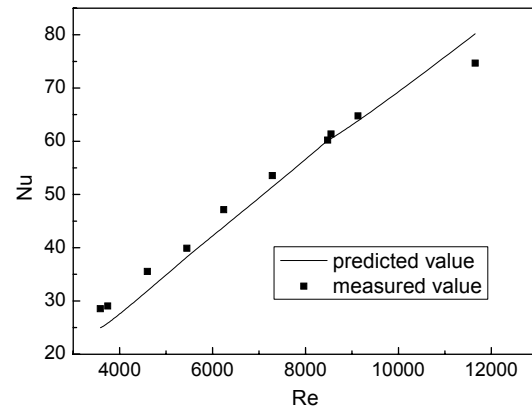

Fig.3 Shell-side heat transfer Nusselt number vs. Reynolds number

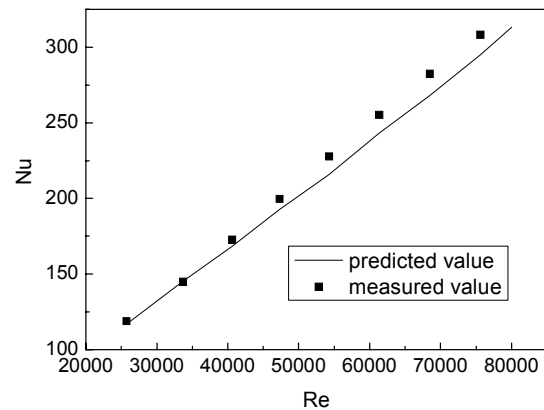

Fig.4 Tube-side heat transfer Nusselt number vs. Reynolds number

## EXPERIMENTAL RESULTS OF FOULING PROCESS

In the present experiments, artificial hardened water is prepared so that the water quality of test liquid could be well controlled. Simulated hard water is confectioned by dissolving a certain quantity of calcium chloride ( $\text{CaCl}_2$ ) and sodium bicarbonate ( $\text{NaHCO}_3$ ) in pure water.

The fouling resistance can be calculated using the following equation:

$$R_f = \frac{1}{k_t} - \frac{1}{k_c} \quad (1)$$

Where  $k_t$  and  $k_c$  are the overall heat transfer coefficients for a heat exchanger with & without fouling respectively.

Experimental study of fouling process has been performed by present authors. Some important parameters including temperature, velocity, water hardness and alkalinity were tested to verify their influences on the fouling process occurred on heat transfer surface.

Fig.5 ~ Fig.9 display the experimental results. It can be observed obviously in the figures that all the fouling resistances vary with time in a similar trend. After a certain time of induction period the fouling resistance increases rapidly within a short time which may be called increasing period, then gets to nearly asymptotic line described as a stabilization period.

Fig.5 and Fig.6 show an important influence of wall temperature and water temperature on fouling resistance. The fouling rate increases rapidly with the increasing of temperatures and final asymptotic fouling resistance gets to a higher level. Fig.7 gives effect of flow velocity on fouling resistance, which decreases with increasing of the flow velocity. When flow velocity is larger than 1.2m/s, the fouling resistance shows a relative static state without any visible variation. The water hardness and alkalinity on fouling resistances are shown in Fig.8 and Fig.9. The fouling rate increases quickly when the water hardness and alkalinity have a high value at the start of the experiments. The phenomena were similar to those reported by other investigators (Kim et al., 2002; Hasson et al., 1968; Helalizadeh et al., 2000).

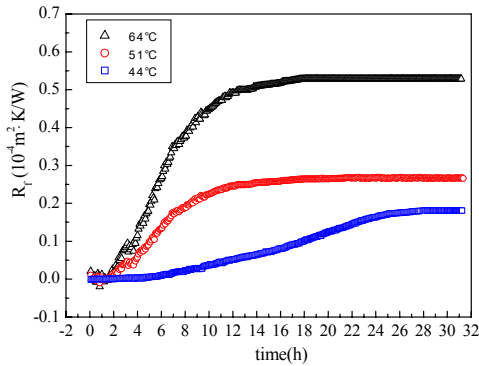

Fig.5 Effect of wall temperature on fouling resistance ( $t_{c1}=22.5^{\circ}\text{C}$ ,  $C=300\text{mg/L}$ ,  $\text{TA}=300\text{mg/L}$ ,  $V_c=1.2\text{m/s}$ )

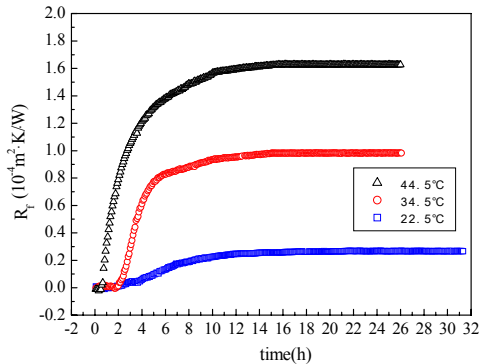

Fig.6 Effect of hard water inlet temperature on fouling resistance ( $t_{h1}=70^{\circ}\text{C}$ ,  $C=300\text{mg/L}$ ,  $\text{TA}=300\text{mg/L}$ ,  $V_c=1.2\text{m/s}$ )

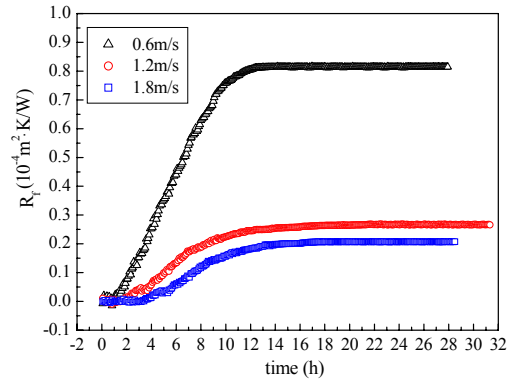

Fig.7 Effect of velocity on fouling resistance ( $t_{h1}=70^{\circ}\text{C}$ ,  $t_{c1}=22.5^{\circ}\text{C}$ ,  $C=300\text{mg/L}$ ,  $\text{TA}=300\text{mg/L}$ )

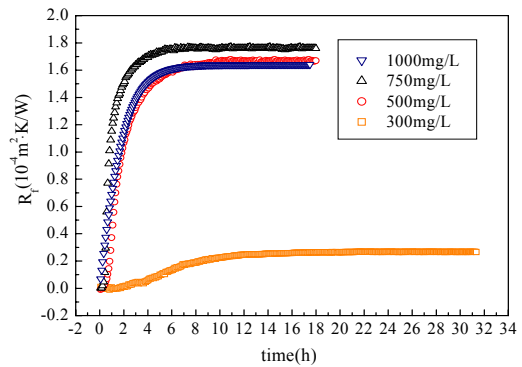

Fig.8 Effect of hardness on fouling resistance ( $t_{h1}=70^{\circ}\text{C}$ ,  $t_{c1}=22.5^{\circ}\text{C}$ ,  $\text{TA}=C$ ,  $V_c=1.2\text{m/s}$ )

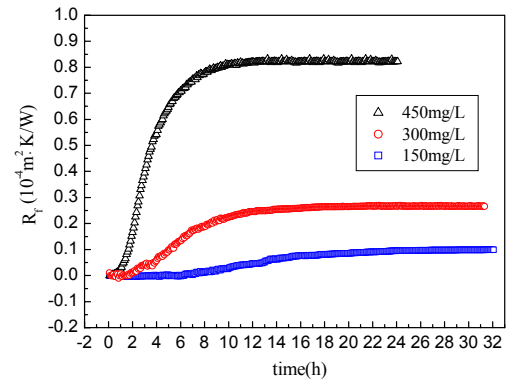

Fig.9 Effect of alkalinity on fouling resistance ( $t_{h1}=70^{\circ}\text{C}$ ,  $t_{c1}=22.5^{\circ}\text{C}$ ,  $C=300\text{mg/L}$ ,  $V_c=1.2\text{m/s}$ )

## PHYSICAL MODEL OF FOULING PROCESS

Based on Kern - Seaton model, present authors provided a new fouling physics model, which includes multi-influences of crystal and particulates fouling of CaCO<sub>3</sub>. Furthermore, it is considered of couple effect of temperature with fouling process. From our experimental results, two kinds of fouling process were observed to occur simultaneously. Fouling crystals formed not only on heat transfer surface but also inside fluid solution, then, particulates produced in solution take part in the fouling process on heated surface. Finally a compound of CaCO<sub>3</sub> crystals and particulates formed layers of scaling. Moreover, wall temperature and fluid temperature varied slowly during fouling process but affected the fouling rates significantly. Since detailed descriptions of the fouling model were given elsewhere (Quan et al., 2007), we will only have simple explanations of the model here.

Kern and Seaton proposed a general form of fouling model including both deposition rate and removal rate of fouling process (Kern, and Seaton, 1959), then Hasson (Hasson et al., 1968) analyzed the crystal fouling in his model. And a common formula for fouling model was adopted by most of researchers as follows:

$$\frac{dR_f}{d\tau} = \frac{m_d - m_r}{\rho_f \lambda_f} \quad (2)$$

where fouling resistance rate can be calculated including fouling deposition rate  $m_d$  and fouling emergence rate  $m_r$ .

As crystals and particulates of CaCO<sub>3</sub> occur simultaneously in fouling process, the compound effect of them should be considered. Present model gives a definition of fouling deposition rates as:

$$m_d = m_c + m_p \quad (3)$$

where  $m_d$  includes effects of crystal fouling rates and particulates fouling rates.

The influences of fouling layer on water temperature and wall temperature were also taken into account in present model based on following heat transfer formula:

$$Q = k\pi d_o L \Delta t_m \quad (4)$$

$$Q = c_h \rho_h U_h (t_{h1} - t_{h2}) \quad (5)$$

$$Q = c_c \rho_c U_c (t_{c2} - t_{c1}) \quad (6)$$

$$\frac{h_c d_c}{\lambda_c} = 0.012(\text{Re}_c^{0.87} - 280) \text{Pr}_c^{0.4} \left[ 1 + \left( \frac{d_c}{L} \right)^{2/3} \right] \left( \frac{\text{Pr}_c}{\text{Pr}_f} \right)^{0.11} \quad (7)$$

$$\frac{h_c d_c}{\lambda_c} = 0.012(\text{Re}_c^{0.87} - 280) \text{Pr}_c^{0.4} \left[ 1 + \left( \frac{d_c}{L} \right)^{2/3} \right] \left( \frac{\text{Pr}_c}{\text{Pr}_f} \right)^{0.11} \quad (8)$$

$$Q = h_h \pi d_i L (t_h - t_{wi}) \quad (9)$$

$$Q = h_c \pi d_o L (t_f - t_c) \quad (10)$$

$$k = \frac{1}{\frac{d_o}{h_h d_i} + \frac{d_o}{2\lambda_{cu}} \ln \frac{d_o}{d_i} + \frac{1}{h_c} + \frac{d_o}{2\lambda_f} \ln \frac{d_f}{d_o}} \quad (11)$$

$$d_f = d_o + 2\delta_f \quad (12)$$

When the cold water inlet temperature  $t_{c1}$  and hot water inlet temperatures  $t_{h1}$  of test section, and the cold water flow rate  $U_c$  and hot water flow rate  $U_h$  maintain invariable, the following unknown variables can be calculated including cold outlet temperature, hot water outlet temperature, heat transfer coefficient  $h_c$  and  $h_h$ , inner wall temperature  $t_{wi}$ , fouling surface temperature  $t_f$  and heat transfer rate  $Q$  according to equations (5-11). Then substitute calculated water temperature and the fouling surface temperature into the fouling deposition and removal model of equations (2-3), and figure out the fouling rate and fouling resistance during the fouling process consequently.

Fig.10 shows the comparison of calculated data from present fouling model and experimental results. A good agreement can be found from the figure and the deviations of calculation results are within 15% of experimental data. As the compound impacts of the particulates and temperatures to fouling process were included, present fouling model is more compatible to real instances of fouling.

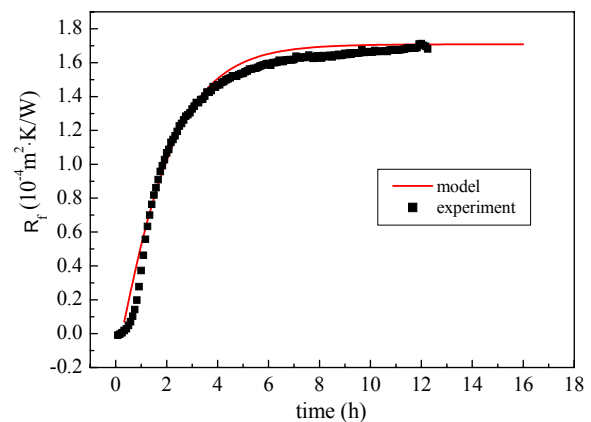

(a)

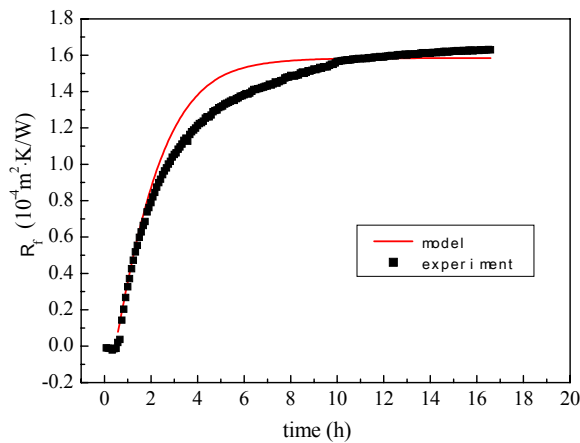

(b)

Fig.10 Comparisons of predictive results of present model and experimental data

(a.  $C=300\text{mg/L}$ ,  $TA=300\text{mg/L}$ ,  $t_{h1}=70^\circ\text{C}$ ,  $t_{c1}=44.3^\circ\text{C}$ ,  $V_c=1.2\text{m/s}$ )

(b.  $C=500\text{mg/L}$ ,  $TA=500\text{mg/L}$ ,  $t_{h1}=70^\circ\text{C}$ ,  $t_{c1}=22.2^\circ\text{C}$ ,  $V_c=1.2\text{m/s}$ )

## CONCLUSIONS

Present work includes experimental and calculated results associated with fouling process in an annular duct. Some major parameters including temperatures, velocity, hardness and alkalinity were tested experimentally to determine their influence on fouling process. Based on kern-seaton model, a new physical model was proposed and good agreements were observed in comparison of predictive results with present experimental data. It should be noted that influence of the induction period of fouling is not included in present model. The work up-to-date in understanding of fouling mechanism is still insufficient. As it is very complex of mechanism of fouling process, much more detailed and deep studies are needed to promote the total resolving fouling problems in heat exchangers.

## NOMENCLATURE

- A area of heat transfer tube,  $\text{m}^2$   
 C water hardness (as  $\text{CaCO}_3$ ),  $\text{mg/L}$   
 c specific heat of water,  $\text{J}/(\text{kg}\cdot\text{K})$   
 $d_o$  outside diameter of heat transfer tube, m  
 $d_i$  inside diameter of heat transfer tube, m  
 h heat transfer coefficient,  $\text{W}/(\text{m}^2\cdot\text{K})$   
 k overall heat transfer coefficient,  $\text{W}/(\text{m}^2\cdot\text{K})$   
 $k_c$  heat transfer coefficient without fouling,  $\text{W}/(\text{m}^2\cdot\text{K})$

$k_t$  heat transfer coefficient with fouling,  $\text{W}/(\text{m}^2\cdot\text{K})$

L length of heat transfer tube, m

$m_c$  crystal fouling rates,  $\text{kg}/(\text{m}^2\cdot\text{s})$

$m_d$  fouling deposition rates,  $\text{kg}/(\text{m}^2\cdot\text{s})$

$m_p$  particulate fouling rates,  $\text{kg}/(\text{m}^2\cdot\text{s})$

$m_r$  fouling emergence rate,  $\text{kg}/(\text{m}^2\cdot\text{s})$

Nu Nusselt number

Pr Prandtl number

Q heat transfer rate, W

Re Reynolds number

$R_f$  fouling resistance,  $\text{m}^2\cdot\text{K}/\text{W}$

t temperature,  $^\circ\text{C}$

TA water alkalinity,  $\text{mg/L}$

$\Delta t_m$  log-mean-temperature difference,  $^\circ\text{C}$

U flow rate,  $\text{m}^3/\text{s}$

V flow velocity, m/s

$\rho$  density,  $\text{kg}/\text{m}^3$

$\lambda$  thermal conductivity,  $\text{W}/(\text{m}^2\cdot\text{K})$

$\delta_f$  thickness of fouling layer, m

$\tau$  time, s

## Subscripts

c cool water

f fouling

h hot water

i inner

o outer

w wall

1 inlet

2 outlet

## REFERENCES

Chen, J., Müller-Steinhagen, H., and Duffy, G. G., 2001, Heat Transfer Enhancement in Dimpled Tubes, Applied Thermal Engineering, Vol.21, pp.535-547.

Hasson, D., Avriel, M., Resnick, W., Rozenman, T., Winderich, S., 1968, Mechanism of calcium carbonate scale deposition on heat transfer surfaces, Ind. Eng. Chem.Fund., Vol.7, pp.59-65.

Helalizadeh, A., H., Steinhagen, H. M., Jamialahmadi, M., 2000, Mixed salt crystallization fouling, Chem. Eng. Process, Vol.39, pp.29-43.

Kern, D. Q. and Seaton, R. E., 1959, A Theoretical Analysis of Thermal Surface Fouling, Chem. Eng. Prog., Vol.4, pp.258-262.

Kim, W.T., Bai, C. and Cho, Y.I., 2002, A study of fouling with a microscopic imaging technique, Int. J. Heat Mass transfer, Vol.45, pp.597-607.

Müller-Steinhagen, H., 1995, Fouling of heat exchanger surfaces, *Chemistry & Industry*, Vol.5, pp.171-175.

Quan, Z.H., Chen, Y.C., Ma, C.F., 2007, Heat and mass model of CaCO<sub>3</sub> fouling on heated surface, accepted by J. China Science.

Somerscales, E.F.C., Knudsen, J.G., 1981, Fouling of heat transfer equipment, Washington, Hemisphere Publishing Corporation, pp.1-25.

Somerscales, E. F. C., 1990, Fouling of Heat Transfer Equipment: A Historical Review, *Heat Transfer Engineering*, Vol.11, pp.19-36.

Steinhagen, R., Steinhausen, H. M. and Maani, K., 1982, Problems and Costs due to Heat Exchanger Fouling in New Zealand Industries, *Heat Transfer Engineering*, Vol.14, pp.19-30.

Taborek, J., Aoki, T., Ritter, R. B., Palen, J.W., Knudsen, J.G., 1972, Fouling: The Major Unresolved Problem in Heat Transfer, *Chem. Eng. Progress*, Vol.68, pp.59-68.

Xing, X.K., 2005, Experimental study and mechanism of calcium carbonate scale deposition on heat transfer surface and electromagnetic anti-fouling, Ph.D Dissertation, Beijing university of technology.

Xing, X.K., Ma, C.F., Chen, Y.C., 2005, Mechanism of Calcium Carbonate Scale Deposition under Subcooled Flow Boiling Conditions, *Chinese Journal Of Chemical Engineering*, Vol.13, pp.464-470.

Yang, S.R., Xu, Z.M. and Sun, L.F., 2004, *Heat Exchanger Fouling and Its Countermeasure*, 2<sup>nd</sup> ed., Science Press, Beijing.